



*Performance from Experience*

---

## **Generic Requirements for Electronic Equipment Cabinets**



Telcordia Technologies Generic Requirements  
GR-487-CORE  
Issue 2  
March 2000

**Comments Requested (See Preface)**

<https://www.reguanli.com>

## Generic Requirements for Electronic Equipment Cabinets

Target audience: This document is intended for the use of manufacturers and end users of Electronic Equipment and Broadband Cabinets.

This document replaces GR-487-CORE, Issue 1, June 1996, and GR-2927-CORE, Issue 1, August 1996.

Technical contacts:

L. M. Slavin, Director  
Telcordia Technologies  
445 South Street, Room 1J136G  
Morristown, NJ 07960-6438

Phone: 1-973-829-4330  
FAX: 1-973-829-5965  
E-Mail: lslavin@telcordia.com

or

E. J. Gallo, Director  
Telcordia Technologies  
445 South Street, Room 1C147G  
Morristown, NJ 07960-6438

Phone: 1-973-829-4638  
FAX: 1-973-829-5965  
E-Mail: egallo@telcordia.com

To obtain copies of this document, contact your company's document coordinator or your Telcordia account manager, or call 1-800-521-2673 (from the USA and Canada) or 1-732-699-5800 (all others), or visit our Web site at [www.telcordia.com](http://www.telcordia.com). Telcordia employees should call 1-732-699-5802.

Copyright © 1996-1999 Telcordia Technologies, Inc. All rights reserved. This document may not be reproduced without the express written permission of Telcordia Technologies, and any reproduction without written authorization is an infringement of copyright.

Project Funding Year: 1999

### Trademark Acknowledgments

Telcordia is a trademark of Telcordia Technologies, Inc.

All other marks and trademarks are the property of their respective companies.

## **Telcordia Technologies Generic Requirements Notice of Disclaimer**

This Generic Requirements document (GR) is published by Telcordia Technologies to inform the industry of the Telcordia view of proposed generic requirements on [Electronic Equipment Cabinets](#). The generic requirements contained herein are subject to review and change, and superseding generic requirements regarding this subject may differ from those in this document. Telcordia reserves the right to revise this document for any reason (consistent with applicable provisions of the Telecommunications Act of 1996 and applicable FCC rules).

Telcordia specifically advises the reader that this GR does not directly or indirectly address any Year-2000 ("Y2K") issues that might be raised by the services, systems, equipment, specifications, descriptions, or interfaces addressed or referred to herein. As an example, and not a limitation, neither this GR nor Telcordia is directly or indirectly assessing or determining whether specific services, systems, or equipment, individually or together, in their current form or as they may be implemented, modified, or augmented in the future, will accurately process dates and date-related data within or between the twentieth and twenty-first centuries, in either direction, including elapsed time, time difference, and/or leap year calculations.

TELCORDIA AND THE FUNDING PARTICIPANTS IDENTIFIED IN THE PREFACE MAKE NO REPRESENTATION OR WARRANTY, EXPRESSED OR IMPLIED, WITH RESPECT TO THE SUFFICIENCY, ACCURACY, OR UTILITY OF ANY INFORMATION OR OPINION CONTAINED HEREIN.

TELCORDIA AND FUNDING PARTICIPANTS EXPRESSLY ADVISE THAT ANY USE OF OR RELIANCE UPON SAID INFORMATION OR OPINION IS AT THE RISK OF THE USER AND THAT NEITHER TELCORDIA NOR ANY FUNDING PARTICIPANT SHALL BE LIABLE FOR ANY DAMAGE OR INJURY INCURRED BY ANY PERSON ARISING OUT OF THE SUFFICIENCY, ACCURACY, OR UTILITY OF ANY INFORMATION OR OPINION CONTAINED HEREIN.

LOCAL CONDITIONS MAY GIVE RISE TO A NEED FOR ADDITIONAL PROFESSIONAL INVESTIGATIONS, MODIFICATIONS, OR SAFEGUARDS TO MEET SITE, EQUIPMENT, ENVIRONMENTAL SAFETY OR COMPANY-SPECIFIC REQUIREMENTS. IN NO EVENT IS THIS INFORMATION INTENDED TO REPLACE FEDERAL, STATE, LOCAL, OR OTHER APPLICABLE CODES, LAWS, OR REGULATIONS. SPECIFIC APPLICATIONS WILL CONTAIN VARIABLES UNKNOWN TO OR BEYOND THE CONTROL OF TELCORDIA. AS A RESULT, TELCORDIA CANNOT WARRANT THAT THE APPLICATION OF THIS INFORMATION WILL PRODUCE THE TECHNICAL RESULT OR SAFETY ORIGINALLY INTENDED.

This GR is not to be construed as a suggestion to anyone to modify or change any product or service, nor does this GR represent any commitment by anyone, including but not limited to Telcordia or any funder of this Telcordia GR, to purchase, manufacture, or sell any product with the described characteristics.

Readers are specifically advised that any entity may have needs, specifications, or requirements different from the generic descriptions herein. Therefore, anyone wishing to know any entity's needs, specifications, or requirements should communicate directly with that entity.

Nothing contained herein shall be construed as conferring by implication, estoppel, or otherwise any license or right under any patent, whether or not the use of any information herein necessarily employs an invention of any existing or later issued patent.

TELCORDIA DOES NOT HEREBY RECOMMEND, APPROVE, CERTIFY, WARRANT, GUARANTEE, OR ENDORSE ANY PRODUCTS, PROCESSES, OR SERVICES, AND NOTHING CONTAINED HEREIN IS INTENDED OR SHOULD BE UNDERSTOOD AS ANY SUCH RECOMMENDATION, APPROVAL, CERTIFICATION, WARRANTY, GUARANTY, OR ENDORSEMENT TO ANYONE.

For general information about this or any other Telcordia documents, please contact:

Telcordia Technologies Customer Service  
Piscataway, New Jersey 08854-4156  
1-800-521-2673 (USA and Canada)  
1-732-699-5800 (all others)  
1-732-336-2559 (FAX)  
<http://www.telcordia.com>

## Contents

Preface . . . . .	Preface-1
1. Introduction . . . . .	1-1
1.1 Purpose and Scope . . . . .	1-1
1.2 Target Audience . . . . .	1-2
1.3 Review/Concurrence Information . . . . .	1-2
1.4 Structure and Use of This Document . . . . .	1-2
1.5 Requirements Terminology . . . . .	1-3
1.6 Requirement Labeling Conventions . . . . .	1-3
1.6.1 Numbering of Requirement and Related Objects . . . . .	1-3
1.6.2 Requirement, Conditional Requirement, and Objective Object Identification . . . . .	1-4
2. General Information . . . . .	2-1
2.1 General Description . . . . .	2-1
2.2 Operating Environment . . . . .	2-1
2.3 Telecommunications Equipment . . . . .	2-2
3. Detailed Requirements . . . . .	3-1
3.1 Product Samples . . . . .	3-1
3.2 Product Changes . . . . .	3-1
3.3 Safety and Reliability Considerations . . . . .	3-1
3.4 Metallic Materials . . . . .	3-2
3.5 Polymeric and Other Non-Metallic Materials . . . . .	3-3
3.6 Finish . . . . .	3-5
3.6.1 Color . . . . .	3-5
3.6.2 Appearance . . . . .	3-6
3.6.3 Paint Adhesion . . . . .	3-6
3.6.4 Flexibility . . . . .	3-7
3.6.5 Paint Adhesion After Exposure . . . . .	3-7
3.6.6 Ultraviolet Resistance . . . . .	3-7
3.7 Screens and Filters . . . . .	3-8
3.8 Door Restrainers (Vertically-Hinged Doors) . . . . .	3-8
3.9 Horizontally-Hinged Doors . . . . .	3-11
3.10 Lifting Details . . . . .	3-13
3.11 Security . . . . .	3-13
3.12 Alarms . . . . .	3-15
3.12.1 General . . . . .	3-15
3.12.2 Engine-Generator . . . . .	3-15
3.13 Condensation . . . . .	3-16
3.14 Fans . . . . .	3-16
3.15 Bonding and Grounding . . . . .	3-17
3.16 AC Power . . . . .	3-17
3.16.1 Commercial Power . . . . .	3-18
3.16.2 Auxiliary Power . . . . .	3-19

3.17	Splicing Compartment . . . . .	3-20
3.18	Electronic Equipment Compartment . . . . .	3-21
3.19	Battery Compartment . . . . .	3-21
3.20	Engine-Generator Compartment . . . . .	3-23
3.21	Pole Mounted, Aerial Cabinets . . . . .	3-25
3.22	Documentation . . . . .	3-25
3.23	Marking, Packaging, and Shipping . . . . .	3-26
3.24	Installation and Maintenance . . . . .	3-27
3.25	Quality . . . . .	3-29
3.26	Exposure to High Temperature . . . . .	3-29
3.27	Thermal Shock . . . . .	3-36
3.28	Water and Dust Intrusion . . . . .	3-39
	3.28.1 Wind Driven Rain . . . . .	3-39
	3.28.2 Rain Intrusion . . . . .	3-39
	3.28.3 Lawn Sprinklers . . . . .	3-40
	3.28.4 Weathertightness . . . . .	3-41
3.29	Acoustical Noise Suppression . . . . .	3-42
3.30	Wind Resistance . . . . .	3-43
3.31	Impact Resistance . . . . .	3-47
3.32	Firearms Resistance . . . . .	3-48
3.33	Fire Resistance . . . . .	3-48
3.34	Corrosion Resistance . . . . .	3-49
	3.34.1 Salt Fog . . . . .	3-49
	3.34.2 Temperature Cycling/High Humidity . . . . .	3-50
3.35	Shock and Vibration . . . . .	3-52
	3.35.1 Transportation Shock . . . . .	3-52
	3.35.2 Transportation Shock (Rail) . . . . .	3-52
	3.35.3 Transportation Vibration . . . . .	3-52
	3.35.4 Installation Shock . . . . .	3-52
	3.35.5 Environmentally Induced Vibration . . . . .	3-53
	3.35.6 Earthquake Resistance . . . . .	3-53
	Appendix A: Observational Standard for Evaluating Dust Accumulation . . . . .	A-1
	References . . . . .	References-1
	Requirement-Object Index . . . . .	ROI-1

## List of Figures

Figure 3-1.	Dynamic Wind Test . . . . .	3-10
Figure 3-2.	Temperature Cycle - Thermal Shock . . . . .	3-38
Figure 3-3.	Application of Force to Pole Mounted Cabinet . . . . .	3-44
Figure 3-4.	Overturning Moment Applied to Pad Mounted Cabinet . . . . .	3-46
Figure 3-5.	Temperature Cycle - Temperature Cycling/High Humidity . . . . .	3-51





## Preface

**This Preface contains important information about the Telcordia Technologies GR process in general, as well as important information about this document.**

### The Telcordia Technologies GR Process

Generic Requirements documents (GRs) provide the Telcordia Technologies view of proposed generic criteria for telecommunications equipment, systems, or services, and involve a wide variety of factors, including interoperability, network integrity, funding participant expressed needs, and other input.

The Telcordia GR process implements Telecommunications Act of 1996 directives relative to the development of industry-wide generic requirements relating to telecommunications equipment, including integral software and customer premises equipment. Pursuant to that Act, Telcordia invites members of the industry to fund and participate in the development process for such GRs. Invitations to fund and participate are issued monthly in the *Telcordia Digest of Technical Information*, and posted on the Telcordia web site at <http://www.telcordia.com/digest>.

At the conclusion of the GR development process, Telcordia publishes the GR, which is available by subscription. The subscription price entitles the purchaser to receive that issue of the GR (GR-CORE) along with any Issues List Report (GR-ILR) and revisions, if any are released under that GR project. ILRs contain any technical issues that arise during GR development that Telcordia and the funding participants would like further industry interaction on. The ILR may present issues for discussion, with or without proposed resolutions, and may describe proposed resolutions that lead to changes to the GR. Significant changes or additional material may be released as a revision to the GR-CORE.

Telcordia may also solicit general industry nonproprietary input regarding such GR material at the time of its publication, or through a special Industry Interaction Notice appearing in the *Telcordia Digest of Technical Information*. While unsolicited comments are welcome, any subsequent work by Telcordia regarding such comments will depend on funding support for such GR work. Telcordia will acknowledge receipt of comments and will provide a status to the submitting company.

## About GR-487-CORE

### A. Funders of GR-487-CORE, Issue 2, are

Anacapa Technology  
BellSouth Telecommunications  
Fujitsu Network Communications  
Lucent Technologies  
Marconi Communications  
U S WEST.

### B. Relative Maturity Level

This is a mature technology and requirements reflect maintenance mode.

### C. GR-487-CORE Plans

None.

## To Submit Comments

When submitting comments, please include the GR document and issue number, and cite any pertinent section and requirement number. Please provide the name and address of the contact person in your company for further discussion.

Send comments to:

L. M. Slavin, Director  
Network Facilities and Components  
Telcordia Technologies  
445 South Street, Room 1J136G  
Morristown, NJ 07960-6438

Phone: 1-973-829-4330  
FAX: 1-973-829-5965  
E-Mail: lslavin@telcordia.com

# 1. Introduction

## 1.1 Purpose and Scope

This document outlines the Telcordia view of proposed generic requirements for electronic equipment and broadband cabinets. The Telcordia view represents the expressed needs and interests of the funding companies of the Telcordia Technical Forum members for this GR (see Preface), and may meet the needs of other telecommunications service providers. The stated requirements are intended to provide a suitable environment for telephone company electronic and broadband equipment that is housed in above ground cabinets, typically pad or pole mounted, in an outside plant environment. The equipment housed in these cabinets is accessible to the craftsperson through surface mounted doors. This document does not cover large cabinets that can be entered by the craftsperson. Although some or all of the requirements in this document may be applicable to a variety of other closures or housings, alternate GR documents may exist for particular applications and shall be considered to provide the relevant criteria for such specific applications. Thus, partially buried pedestal type terminals, Optical Network Units, or cabinets containing Building Entrance Terminals that serve as a demarcation point between the public telephone network and the customer premises are specifically covered by other documents. In general, GR-487-CORE and these documents take precedence over other documents that may indicate requirements for cabinets deployed in the outside plant environment. Similarly, GR-63-CORE<sup>[1]</sup>, *Network Equipment-Building System (NEBS) Requirements: Physical Protection*, defines requirements for equipment used within the Central Office environment. The following documents complement the information in this document:

GR-13-CORE<sup>[2]</sup>, *Generic Requirements for Pedestal Terminal Closures*, outlines the requirements for partially buried closures that provide access to telecommunications distribution points.

GR-26-CORE<sup>[3]</sup>, *Generic Requirements for Controlled Environment Vaults (CEVs)*, outlines the requirements for below ground structures that utilize an air conditioning system to provide a suitable environment for equipment and craft.

GR-43-CORE<sup>[4]</sup>, *Generic Requirements for Telecommunications Huts*, outlines the requirements for above ground buildings that utilize an air conditioning system to provide a suitable environment for equipment and craft.

GR-937-CORE<sup>[5]</sup>, *Generic Requirements for Building Entrance Terminals*, outlines the requirements for Outdoor Building Entrance Terminals and Indoor Building Entrance Terminals equipped with protector units.

GR-950-CORE<sup>[6]</sup>, *Generic Requirements for Optical Network Unit (ONU) Closures*, outlines the requirements for closures containing the optical-metallic interface at the customer end of a Fiber-in-the-Loop system.

GR-2832-CORE<sup>[7]</sup>, *Generic Requirements for Walk-In Cabinets*, outlines the requirements for partially buried cabinets that utilize an air conditioning system for equipment cooling and can be entered by craft.

## 1.2 Target Audience

This document is intended for the use of manufacturers and end users of Electronic Equipment and Broadband Cabinets.

## 1.3 Review/Concurrence Information

This document is being reissued to clarify the stated requirements and related test procedures and to incorporate broadband cabinet requirements into a single document. For the present purposes, broadband equipment is considered to be that capable of providing subscriber services at very high frequencies or bit rates (e.g., greater than DS3 / 45 Mbs), typically delivered over coaxial or fiber media. The current broadband cabinet document (GR-2927-CORE) will be superseded and replaced by this new issue of GR-487-CORE. Thus, Issue 2 includes additional requirements for the splicing compartment, which may serve coaxial or fiber media, as well as requirements for a permanent engine-generator. Requirements related to touch temperature, wind loads, and temperature extremes are examples of other areas that have been significantly modified or expanded. Due to the extensive modifications, additions, rearrangements, and re-numbering of requirements, the changes are not explicitly highlighted in the text.

## 1.4 Structure and Use of This Document

The information contained in this document is divided into three principle parts. Section 1 outlines the purpose, scope, target audience, structure, reason for reissue and terminology. Section 2 provides product description and application information. Section 3 outlines features, functions and performance requirements and related test procedures.

This generic requirements document should be used in conjunction with a telecommunications equipment and broadband systems specification. The systems specification should detail the identification and location of all housed components and the requirements for those components as they relate to the cabinet in which they are to be housed.

## 1.5 Requirements Terminology

The following requirements terminology is used throughout this document:

- **Requirement** — Feature or function that, in the view of Telcordia, is *necessary* to satisfy the needs of a typical user. Failure to meet a requirement may cause application restrictions, result in improper functioning of the product, or hinder operations. A Requirement contains the words *shall* or *must* and is flagged by the letter “**R**.”
- **Conditional Requirement** — Feature or function that, in the view of Telcordia, is *necessary in specific applications*. If a user identifies a Conditional Requirement as necessary, it shall be treated as a requirement for the application(s). Conditions that may cause the Conditional Requirement to apply include, but are not limited to, certain user’s application environments, elements, or other requirements, etc. A Conditional Requirement is flagged by the letters “**CR**.”
- **Objective** — Feature or function that, in the view of Telcordia, is *desirable* and may be required by a user. An Objective represents a goal to be achieved. An Objective may be reclassified as a Requirement at a specified date. An objective is flagged by the letter “**O**” and includes the words *it is desirable* or *it is an objective*.
- **Conditional Objective** — Feature or function that, in the view of Telcordia, is *desirable in specific applications* and may be required by a user. It represents a goal to be achieved in the specified Condition(s). If a client company identifies a Conditional Objective as necessary, it shall be treated as a requirement for the application(s). A Conditional Objective is flagged by the letters “**CO**.”
- **Condition** — The circumstances that, in the view of Telcordia, will cause a Conditional Requirement or Conditional Objective to apply. A Condition is flagged by the letters “**Cn**.”

## 1.6 Requirement Labeling Conventions

As part of the Telcordia GR Process, proposed requirements and objectives are labeled using conventions that are explained in the following two sections.

### 1.6.1 Numbering of Requirement and Related Objects

Each Requirement, Objective, Condition, Conditional Requirement, and Conditional Objective object is identified by both a local and an absolute number. The local number consists of the object's document section number and its sequence number in the section (e.g., **R3-1** is the first Requirement in Section 3). The local number appears in the margin to the left of the Requirement. A Requirement object's local number may change in subsequent issues of a document if other Requirements are added to the section or deleted.

The absolute number is a permanently assigned number that will remain for the life of the Requirement; it will not change with new issues of the document. The absolute number is presented in brackets (e.g., **[2]**) at the beginning of the requirement text.

Neither the local nor the absolute number of a Conditional Requirement or Conditional Objective depends on the number of the related Condition(s). If there is any ambiguity about which Conditions apply, the specific Condition(s) will be referred to by number in the text of the Conditional Requirement or Conditional Objective.

References to Requirements, Objectives, or Conditions published in other Generic Requirements documents will include both the document number and the Requirement object's absolute number. For example, **R2345-12** refers to Requirement **[12]** in GR-2345-CORE.

### **1.6.2 Requirement, Conditional Requirement, and Objective Object Identification**

A Requirement object may have numerous elements (paragraphs, lists, tables, equations, etc.). To aid the reader in identifying each part of the requirement, an ellipsis character (...) appears in the margin to the left of all elements of the Requirement.

Tables and Figures within Requirements are identified separately from others within the document text, and do not appear in the Table of Contents. They are numbered sequentially within each section.

## 2. General Information

### 2.1 General Description

A cabinet, as defined in this document, is an above ground enclosure constructed of either metallic or nonmetallic materials, or a combination thereof, sized to house telecommunications equipment, including broadband, ranging from active electronic and optical systems to passive mechanical cross-connect and splicing fields, as well as backup power. These cabinets provide mechanical and environmental protection for the equipment contained within, allow access for craftspersons work activities and discourage access by unauthorized persons. Cabinet cooling is provided by various means including, but not limited to, external natural convection, radiation, internal convection or forced air circulation, fan-forced heat exchangers, or various combinations of such cooling methods. Cabinets may be pad mounted, pole mounted, wall or stub pole mounted, or may be designed for some other mode of installation.

Considering the complexity of many present day loop electronic carrier systems and broadband systems, these cabinets may be separated into discrete compartments to accommodate different craftspersons' work activities and different equipment. Various sections, possibly isolated, may be required for certain applications including a compartment or section for

- Electronic equipment
- Commercial power entrance
- Back-up battery power
- Generator set
- Cable splicing
- Cross-connect field.

### 2.2 Operating Environment

Electronic equipment cabinets are designed to withstand climatic conditions existing throughout the United States including rain, snow, sleet, high winds, ice, salt spray and sand storms. Ambient temperatures ranging from  $-40^{\circ}\text{C}$  ( $-40^{\circ}\text{F}$ ) to  $46^{\circ}\text{C}$  ( $115^{\circ}\text{F}$ ), with varying degrees of solar loading, and humidity levels ranging from below 10% up to 100%, can be encountered. These temperatures are examples and do not necessarily encompass all possible climatic or deployment conditions. Some locations or applications may experience higher temperatures or lead to more severe thermal conditions; some geographic locations may be prone to earthquakes or particularly severe lightning storms. In some cases, requirements for specific areas are provided as conditional requirements.

## 2.3 Telecommunications Equipment

Cabinet applications range from housings for active equipment such as Digital Loop Carrier, Digital Subscriber Loop (DSL), broadband, or electro-optic interfaces, to power and repeater cabinets, to cabinet enclosures containing passive hardware such as cross-connect fields between feeder and distribution cables designated as Feeder Distribution Interfaces (FDIs). [Section 1.1](#) describes the type housings covered by this document as well as structure and enclosure applications that are not covered. Generic requirements for the housed telecommunications equipment are contained in separate documents.

This generic requirements document should be used in conjunction with a telecommunications equipment and broadband systems specification. The systems specification should detail the identification and location of all housed components and the requirements for those components as they relate to the cabinet in which they are to be housed.



### 3. Detailed Requirements

#### 3.1 Product Samples

- R3-1** [1] Samples provided for all product analyses against this document should be representative of currently manufactured and marketed products. If pre-production samples are provided, they shall be identified as such and so noted in the test report. Future production may be inspected by the customer or its agent.
- R3-2** [2] Samples provided for all product analyses shall be clearly identified (manufacturer's name, model or part number and date code) and shall include appropriate documentation. A permanent label or equivalent, with the aforementioned information shall typically be located in the electronic equipment compartment of the cabinet.
- R3-3** [3] For the evaluation process, component parts provided for the product analyses tests identified in this GR, shall be identified with the cabinet model number in which the parts are used.

#### 3.2 Product Changes

- R3-4** [4] The supplier shall provide the customer with proper notification (Product Change Notice or PCN) of all product changes including changes in materials used to manufacture the product. The procedures outlined in GR-209-CORE<sup>[8]</sup> shall be followed.

#### 3.3 Safety and Reliability Considerations

- R3-5** [5] The cabinet shall be free of hazards, such as sharp edges, burrs, etc., that could present a safety hazard to personnel involved in the assembly, installation, use or maintenance of the cabinet.
- R3-6** [6] Product integrity shall be maintained and there shall be no deviations that will degrade the product with respect to safety, reliability, interchangeability, life, performance, operation, quality, protectants, and maintenance. The manufacturer shall make any proposal to the customer that will improve the product with respect to safety, reliability, interchangeability, life, performance, quality, protectants and maintenance.
- R3-7** [7] Products shall be manufactured and used in accordance with the following requirements or standards as applicable: Federal

Communications Commission (FCC), National Electrical Code (NEC), Underwriters' Laboratories (UL), and Department of Labor - Occupational Safety and Health Administration (OSHA). Other federal, state and local requirements including, but not limited to statutes, rules, regulations, orders or ordinances, or otherwise imposed by law may apply.

- R3-8** [8] Materials in the product shall present no environmental hazard as defined by current industry standards or applicable laws and regulations.
- R3-9** [173] The exposed surfaces of the cabinet shall not represent a hazard to the public or craftspersons. Under the test conditions of **CR3-189**, surface temperatures of the exterior of the cabinet shall meet the following requirements: metallic surfaces shall not exceed 70°C (158°F) and polymeric surfaces shall not exceed 130°C (266°F). When performing **R3-187**, the maximum temperature of interior accessible items, including hardware or equipment (including circuit pack face plates), and surfaces other than the inside surfaces of the outer cabinet structure or doors, shall meet the following requirements: metallic surfaces shall not exceed 70°C (158°F) and polymeric surfaces shall not exceed 130°C (266°F), unless warning labels are provided.

### 3.4 Metallic Materials

In general, metallic materials used in cabinet construction shall be resistant to various forms of corrosion, including general and localized corrosion, as well as galvanic effects associated with dissimilar metals. The tests indicated in Section 3.34 shall be used to verify such resistance. Specific requirements related to metallic usage are indicated below.

- CR3-10** [9] Some customers require that the supplier identify the types of metallic materials used to fabricate cabinet components and their properties.
- R3-11** [34] Threaded, carbon-steel pad or pole mounting hardware shall be zinc-plated per ASTM A 153<sup>[9]</sup>.
- R3-12** [35] Threaded, corrosion resistant (stainless) steel pad or pole mounting hardware, as well as exposed stainless steel cabinet components, shall be passivated to remove surface impurities.

### 3.5 Polymeric and Other Non-Metallic Materials

**CR3-13** [12] Some customers require that the supplier identify the types of polymeric materials and other nonmetallic materials used to fabricate cabinet components and their properties.

**R3-14** [13] Cabinet components of polymeric materials shall be free of stress cracks, stripping, molting, texture or color change after exposure to the chemicals stated below.

Test Procedure – Each polymeric part, or a test specimen of minimum size 5 cm x 5 cm (2 in x 2 in) cut from the cabinet component material shall be thoroughly saturated with the following test chemicals for a period of 30 days and then inspected for the stated defects. A minimum of three samples of each part shall be exposed.

- ... • 3% H<sub>2</sub>SO<sub>4</sub> (Sulfuric Acid)
- ... • 0.2N NaOH (Sodium Hydroxide)
- ... • NH<sub>3</sub> (Household Ammonia)
- ... • 90% Isopropyl Alcohol
- ... • Kerosene (flash point greater than 71° C (160° F) per ASTM D 56<sup>[10]</sup>)
- ... • 10% Igepal CO-630, CO-520 or CO-720 per ASTM D 1693<sup>[11]</sup>.

Upon completion of the test, there shall be no visible deterioration (stress cracking, blistering, delamination of the surface, discoloration).

**CR3-15** [14] Some customers require that non-metallic materials meet **R3-14** when exposed to specific products used by their craft. These products will be specified by the customer and may include

- ... • Cable filling compounds
- ... • Cable cleaning fluids
- ... • Fiber optic splice cleaning fluids
- ... • Water displacing lubricants
- ... • Insect sprays.

**R3-16** [15] Polymeric materials parts shall be non-corrosive to metals and shall be compatible with other materials used in the manufacture of the cabinet.

**R3-17** [16] Parts made of polymeric materials (excluding insulated wire, cable and foam gasket materials) shall have a minimum flammability

rating of 94 V-1 when tested per UL 94<sup>[12]</sup>. This requirement does not apply to components smaller than 20 cm<sup>3</sup> (approximately 1 in<sup>3</sup>) in volume since this is not considered to represent a significant fuel load.

**R3-18** [174] Internal insulated wire and cable used within the cabinet shall meet the flammability requirements of UL 1581<sup>[13]</sup> when tested in accordance with the VW-1 Vertical Flame Test.

**R3-19** [175] Foam gasket materials used internal to the cabinet shall meet the 94 HF-1 flammability requirement of UL 746C<sup>[14]</sup>.

**R3-20** [17] Any part of the exterior housing, if polymeric, shall have a flammability rating of 94-5V when tested per UL 94.

**R3-21** [18] All cabinet components made from polymeric compounds shall be resistant to fungus growth. They shall have a fungus growth rating of zero when tested according to ASTM G 21<sup>[15]</sup>.

Test Procedure - Three samples of each component made from polymeric compounds shall be tested per ASTM G 21.

**R3-22** [19] Exterior polymeric materials components that may be exposed to sunlight, including seals and gaskets, shall be resistant to ultraviolet degradation. Following exposure per ASTM G 53<sup>[16]</sup>, the samples shall retain 75% of their original tensile strength. Seals and gaskets exposed to the same conditions shall show no signs of hardening or brittleness as determined by hand flexing.

Test Procedure - A minimum of six tensile test samples of each polymeric materials material (excluding seals and gaskets) shall be tested per ASTM D 638<sup>[17]</sup> to determine the breaking strength for unexposed samples. Six additional samples shall be exposed to UV light and condensation per ASTM G 53 using UVB-313 lamps and subsequently tested for breaking strength. A repetitive cycle of 4 hours UV light at 60° C (140° F) followed by 4 hours condensation (UV light off) at 50° C (122° F) shall be used for a total test time of 1000 hours. UVA-340 lamps may be used in place of UVB-313 lamps, providing the total test time is increased to 2000 hours. Seals and gaskets shall receive the same exposure.

**R3-23** [20] Seals and gaskets shall retain their physical characteristics after oven aging.

Test Procedure - Seal and gasket sample parts shall be aged at a temperature of 70° C (158° F) in a circulating air oven for a period of 168 hours. Following this exposure, there shall be no visible deterioration, deformation, melting or cracking of the aged samples and they shall not harden as determined by hand flexing.

**R3-24** [21] Components manufactured from rubber compounds, such as seals and gaskets, shall show no signs of surface ozone cracking.

Test Procedure - Test samples shall be prepared as stated in Method A of ASTM D 518<sup>[18]</sup>. Samples shall be exposed for 70 hours at  $40 \pm 1^{\circ}$  C ( $104 \pm 2^{\circ}$  F) at an ozone level of  $50 \pm 5$  mPa partial ozone pressure using the ozone test apparatus described in ASTM D 1149<sup>[19]</sup>. Samples shall show no signs of cracking when observed under 2X magnification after this exposure.

**R3-25** [22] The adhesives used on seals and gaskets shall maintain adhesive qualities, including no visible indication of movement, and function properly after exposure to environmental extremes and other shocks.

Test Procedure - Upon completion of the various test procedures for the Requirements (**R**) specified in

- ... • [Section 3.26, Exposure to High Temperature](#)
- ... • [Section 3.27, Thermal Shock](#)
- ... • [Section 3.28, Water and Dust Intrusion](#)
- ... • [Section 3.32, Firearms Resistance](#)
- ... • [Section 3.33, Fire Resistance](#)
- ... • [Section 3.34, Corrosion Resistance](#)
- ... • [Section 3.35, Shock and Vibration](#)

the adhesives shall be examined. There shall be no deterioration of the adhesives based upon physical and visual examination of the seals, nor any indication of shifting of gaskets.

## 3.6 Finish

### 3.6.1 Color

**R3-26** [23] The manufacturer shall utilize Master Color Standards to identify available cabinet colors. The color of each standard shall be characterized using the CIELAB system of color notation as described in ASTM D 2244<sup>[20]</sup>. If the customer requires a cabinet color differing from that normally available, an appropriate Master Color Standard shall be utilized.

**R3-27** [25] The color of production cabinets shall be measured periodically to confirm compliance with the Master Color Standard. The maximum permissible variations from the Master Color Standard

are  $\pm 1.0$  for  $\Delta L$ ,  $\Delta a$  and  $\Delta b$  values and  $\pm 1.5$  for  $\Delta E$  using the CIELAB system of color notation as described in ASTM D 2244.

- R3-28** [26] The supplier shall provide touch-up paint for all painted exterior/interior metallic components of the cabinet in a convenient container as specified by the customer. This paint shall match the applicable Master Color Standard as stated in **R3-26**. The cabinet documentation shall contain ordering and application information for the paint.

### 3.6.2 Appearance

- R3-29** [27] Painted metallic housings shall have a gloss ( $60^\circ$  Specular) of 60 (minimum) in accordance with ASTM D 523<sup>[21]</sup>.

Test Procedure - Two 20 cm x 20 cm (8 in x 8 in) samples of cabinet material finished with each color paint shall be prepared by the manufacturer to be representative in material type, surface finish treatment and thickness of finish. Gloss shall be measured in accordance with procedures of ASTM D 523.

- R3-30** [28] The exterior and interior surfaces of painted cabinets shall have a uniform color and texture.

- R3-31** [29] In the case of polymeric materials cabinets, the outside surface appearance shall meet the general industry standards on optical requirements for gloss and haze as applicable to the particular polymer.

### 3.6.3 Paint Adhesion

- R3-32** [30] Finishes of painted metal surfaces shall be subjected to a scrape adhesion test. There shall be no removal or separation of paint particles or breaking of the finish by the scraping loop to the extent of exposing the secondary finish (e.g., galvanizing).

Test Procedure - Two 20 cm x 20 cm (8 in x 8 in) samples of cabinet material finished with each color paint shall be prepared by the manufacturer to be representative in material type, surface finish treatment and thickness of finish. Tests shall be conducted in accordance with ASTM D 2197<sup>[22]</sup> on the top (finish) coat using a 8 kg (17.5 lb) load on the scraping loop.

### 3.6.4 Flexibility

- R3-33** [31] The finish on painted metal surfaces shall not exhibit radial cracking when subjected to an impact test in accordance with ASTM D 2794<sup>[23]</sup>.

Test Procedure - Two 20 cm x 20 cm (8 in x 8 in) samples of cabinet material finished with each color paint shall be prepared by the manufacturer to be representative in material type, thickness, surface finish treatment and thickness of finish. The test shall otherwise be conducted in accordance with ASTM D 2794 using an impact of 18 J (160 in-lb) and a 1.59 cm (0.625 in) diameter indenter.

### 3.6.5 Paint Adhesion After Exposure

- R3-34** [32] The finish on painted metal surfaces shall demonstrate satisfactory adhesion when tested in accordance with ASTM D 1654<sup>[24]</sup>, including exposure to salt fog.

Test Procedure - Two 20 cm x 20 cm (8 in x 8 in) samples of cabinet material finished with each color paint shall be prepared by the manufacturer to be representative in material type, thickness, surface finish treatment and thickness of finish. The samples shall be scribed to bare metal as described in ASTM D 1654. Each sample shall have a minimum combined scribe length of 64 cm (25 in). The samples shall then be exposed to salt fog per ASTM B 117<sup>[25]</sup> for a period of 30 days. Samples shall be oriented so that droplets run across the scribe marks. The samples shall be evaluated per Procedure A, Method 2 of ASTM D 1654 after exposure. A minimum rating of 7 is required at the scribes.

### 3.6.6 Ultraviolet Resistance

- R3-35** [33] Samples of each exterior metallic material shall be exposed to UV light and condensation per ASTM G 53. After exposure, the panels shall meet the Flexibility (**R3-33**) criteria.

Test Procedure - Two samples prepared as described in **R3-33** shall be exposed to UV light and condensation per ASTM G 53 using UVB-313 lamps and a repetitive cycle of 4 hours UV light at 60° C (140° F) followed by 4 hours condensation (UV light off) at 50° C (122° F) for a total test time of 1000 hours. UVA-340 lamps may be used in place of UVB-313 lamps, providing the total test time is increased to 2000 hours. Samples shall then be subjected to the Flexibility requirement, **R3-33**.

### 3.7 Screens and Filters

- R3-36** [36] Cabinet cooling systems using outside air, such as heat exchangers, shall minimize the need for replacing or washing screens or air filters. The supplier's documentation shall cover maintenance and/or replacement of the screens or filters, as appropriate.
- R3-37** [37] Non-corrosive, non-flammable screens, filters or other means shall be used on all inlet and outlet ventilation openings in the cabinet to minimize the entrance of dust and insects. The supplier's documentation shall cover maintenance and/or replacement of the screens or filters, as appropriate.
- R3-38** [38] Screened areas shall inhibit the entrance of water.
- R3-39** [39] The cabinet shall effectively drain moisture which may enter through screens or other means. Drain holes or openings in the cabinet shall be resistant to clogging and minimize the entrance of dust and insects. (See **R3-138** and [Section 3.28, Water and Dust Intrusion.](#))

### 3.8 Door Restrainers (Vertically-Hinged Doors)

- R3-40** [40] Cabinet doors shall be equipped with a corrosion resistant device that restrains the doors in an open position. (Cabinets may incorporate multiple open positions.)
- R3-41** [41] The door restraining device shall be self activating when the doors are opened and shall be released manually in order to close the doors. Door restrainers shall minimize audible "rattling" when in the engaged position.
- R3-42** [42] The cabinet and door restraints shall be capable of withstanding, without mechanical damage or loss of function, the opening and closing forces resulting from a wind speed of 22 m/sec (50 mph).

Test Procedure - The cabinet shall be mounted consistent with the manufacturer's instructions. The door shall be held in the open position by the door restraining device. A force **F** shall be applied to the outer edge of the door, perpendicular to the door surface, in both the opening and closing direction, in turn. The force shall be applied by means of a tensioning device (e.g., winch coupled with a force meter) and shall be maintained for a minimum of ten seconds in each direction. The time to fully achieve the peak force **F** shall be greater than 30 seconds. The test shall be performed for each possible open-restrained position. The force **F** is calculated as follows



$$\mathbf{F} = 0.025 \mathbf{WH}$$

where

**F** = force, lbs

**W** = door width, inches

**H** = door height, inches.

- R3-43** [176] The cabinet and door restraints shall be capable of withstanding, without mechanical damage or loss of function, the dynamic impact loads resulting from a wind speed of 13 m/sec (30 mph) swinging the door open prior to activation of the door restraints.

Test Procedure - The cabinet shall be mounted consistent with the manufacturer's instructions. The cabinet door shall be temporarily maintained in a position 30° prior to the engaged open position. (If there are several open engaged positions, the test shall be performed for each local position. In this case, the cabinet door shall be temporarily maintained in a position 30° prior to the local engaged open position, but not at or below the previous engaged position.) A force **F** shall be applied by means of stretching a long spring to the outer edge of the door in its temporarily maintained position, tending to pull the door open, as indicated in Figure 3-1. The force **F** is calculated as follows:

$$\mathbf{F} = 0.010 \mathbf{WH}$$

where

**F** = force, lbs

**W** = door width, inches

**H** = door height, inches.

The spring shall be anchored a minimum distance 5W away from the hinge of the door (Figure 3-1). The door shall be released from its temporary open position and allowed to swing open until restrained by either the door restraints or the hinge hardware. The spring shall have a maximum stiffness (spring constant) of 5 lbs/ft. All reasonable safety precautions shall be followed to ensure personnel are not be subject to dangers resulting from the dynamic motion of the spring or door.

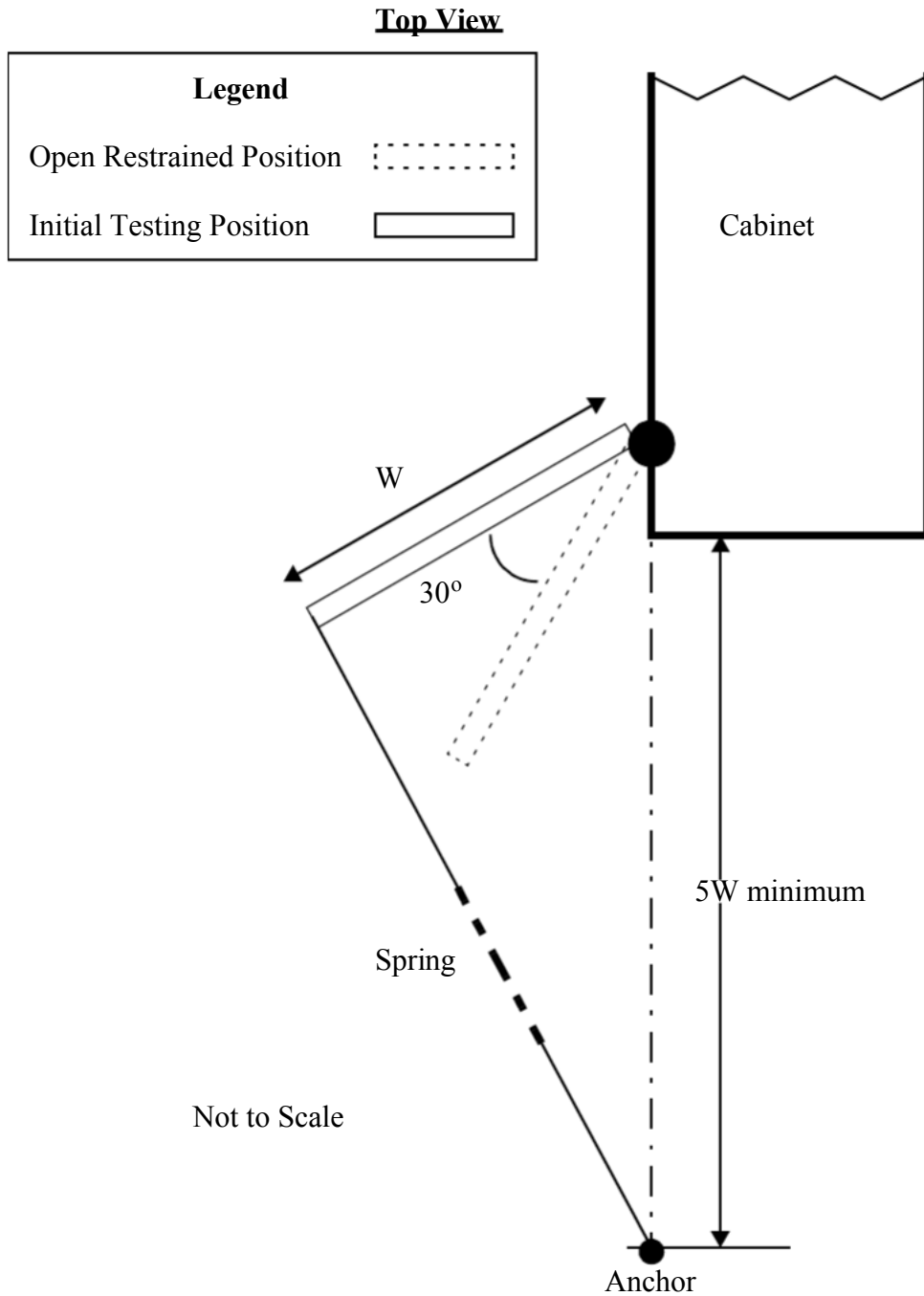

**Figure 3-1.** Dynamic Wind Test

- O3-44** [177] It is desirable that the cabinet be capable of withstanding, without mechanical damage or loss of function, the dynamic impact loads resulting from a wind speed of 22 m/sec (50 mph) swinging the door open prior to activation of the door restraints.

Test Procedure – The procedures outlined in **R3-43** shall be applied, except the force **F** is calculated as follows:

$$F = 0.025 WH$$

where

**F** = force, lbs

**W** = door width, inches

**H** = door height, inches.

### 3.9 Horizontally-Hinged Doors

- R3-45** [43] A maximum force of 13.6 kg (30 lbs) shall be required to lift or close a horizontally hinged (raised) door.

Test Procedure - The door shall be unlocked and the lifting force applied in the recommended manner. The required force shall be recorded as the door is raised to its full open position and again while closing the door.

- R3-46** [44] For cabinets using a mechanical assist system to meet requirement **R3-45**, the system shall meet this requirement at -40° C (-40° F) and 60° C (140° F), after soaking and stabilization at these temperatures.

- R3-47** [45] For cabinets using a mechanical assist system to meet requirement **R3-45**, the system shall function properly and be free of excessive wear after repeated door operations.

Test Procedure - The door shall be opened and closed 3,000 times, and then be visually checked for excessive component wear. Requirement **R3-45** must be met after the 3,000 open/close cycles.

- R3-48** [46] In the event of failure of the mechanical assist system, it shall be possible to lift the door to its full open position by applying a maximum lifting force of 18.1 kg (40 lbs) at each of the door's lower corners.

Test Procedure - The door shall be unlocked and the lifting force applied at each corner of the door along its bottom edge. The forces shall be applied perpendicular to the door surface and be recorded as the door is raised to its full open position.

- R3-49** [47] A door support mechanism, with a positive engagement feature, as opposed to the use of friction, springs or gas charged cylinders, shall be provided to hold the door in its full open position. This mechanism shall engage automatically and shall require manual disengagement.
- R3-50** [48] The door support mechanism shall engage to prevent the door from dropping when the lifting force is removed, during the door lifting procedure.
- R3-51** [49] The door support mechanism shall function properly and be free of excessive wear after repeated door operations.
- Test Procedure - The door shall be opened and closed 3,000 times. After the 3,000 open/close cycles, with the door in the full open position, a force equal to three times the weight of the door (minimum of 90.7 kg [200 lbs]) shall then be applied at the center of the door. The force shall be applied perpendicular to the door surface for a minimum of 10 seconds. There shall be no failure or permanent yielding of components as a result of this test.
- R3-52** [50] The door shall open a minimum of 90° so that its full open position is in (or above) a plane passing through the door's hinges and parallel to the cabinet's mounting surface. This ensures that the lowest edge of the door is at the hinge and adequate headroom is provided.
- R3-53** [51] There shall be a minimum clear height of 1.93 m (6 ft-4 in) at a distance of 61 cm (2 ft) from the cabinet with the door in its full open position.
- R3-54** [52] For cabinets in which the bottom edge of the fully open door is more than 1.73 m (5 ft-8 in) above the cabinet mounting surface, a means (within that reach) shall be provided to allow pulling the door to a reachable height.
- CR3-55** [53] Some customers require that the door provide a means to attach a curtain to its outer edges to provide additional protection during inclement weather.
- R3-56** [55] The cabinet shall be properly guttered to ensure that water running off of the fully opened, raised door will not enter the electronics chambers of the cabinet.
- Test Procedure - Spray head piping as described in UL 497<sup>[26]</sup>, Figure 20.1, shall be utilized. The center spray head shall be positioned at the center of the open door and at a distance of 1.22 m (4 ft) from the door surface. Piping shall run parallel to the door's width. Spray

shall be applied for 30 minutes using 207 kPa (30 psi) spray head pressures.

### 3.10 Lifting Details

**R3-57** [56] Any cabinet packaged for shipping and weighing in excess of 90.7 kg (200 lbs) shall be provided with means, such as eye bolts, for attaching hoisting lines. Lifting details shall be clearly specified in installation practice. Eyebolts shall be positioned to allow for stable, balanced and level movement of cabinet.

**R3-58** [57] Eyebolts or screws used for lifting shall not protrude through the cabinet housing and into the interior of the cabinet. Eyebolts shall be removable after installation if they protrude above the cabinet surface. If removed, substitute non-corrosive caps shall be provided. The caps shall meet material requirements specified in this document. The removal of the eyebolts shall not result in an increased risk of corrosion.

**R3-59** [58] For any cabinet (as shipped) weighing more than 90.7 kg (200 lbs), there shall be no visible deformation or damage to the cabinet when the lifting attachments are loaded to three times the weight of the fully equipped cabinet (excluding packaging materials and skid). When loaded to six times the weight of the fully equipped cabinet, there shall be no catastrophic failure of the lifting details.

**Note:** The fully-equipped cabinet includes only the equipment inside the cabinet at the time of shipment. The supplier provided installation practice shall clearly identify equipment that is not included in cabinet at time of shipment and cabinet installation (e.g., batteries, circuit packs, etc.).

**Test Procedure -** The cabinet shall be bolted to a restraining member such as a concrete slab and then subjected to a lifting load, through the lifting attachments, equal to three and then six times the weight of the fully equipped cabinet. (The application of the six times load to the lifting attachments may require bracing of the cabinet. Such bracing shall not reinforce the lifting attachments.)

### 3.11 Security

**R3-60** [59] All hinged exterior doors shall be locked through use of a multi-point locking mechanism to ensure that all door corners and edges are secure. The mechanism shall have sufficient clearance from all gaskets, equipment and other cabinet surfaces to insure proper

operation even if the cabinet is off-level, but within the limits specified by the manufacturer for proper installation.

- O3-61** [60] It is desirable to use a single, multi-point locking mechanism on all exterior doors. Fasteners on all moving parts shall not fall off or loosen under normal use.
- CR3-62** [178] Some customers require a provision for adding an auto-lock mechanism to the cabinet.
- CR3-63** [61] Some customers require that all exterior doors and removable access panels have provision for a padlock. In such cases, the padlock hasp shall accept a 0.64 cm (1/4 in) diameter padlock shackle. The normal use of the padlock shall not result in damage to any painted surface.
- R3-64** [62] In order to ensure access by only authorized personnel, the hinged door locking mechanism shall be activated by a special security tool that cannot be readily purchased or duplicated.
- CR3-65** [63] Some customers require a specific security tool to minimize the number of tools carried by the craft.
- R3-66** [179] The door locking hardware and mechanism shall be capable of withstanding anticipated torque levels, without physical distortion, damage, or loss of functionality.
- Test Procedure - A torque of 400 in-lbs minimum shall be applied to the door opening hardware by means of the manufacturer specified tool and a commercially available torque tester, and be maintained for a minimum of 5 seconds and then released. This procedure shall be repeated a total of 10 times. Manually operated door handles shall also be subject to the same torque level, duration, and number of cycles.
- R3-67** [64] The door locking mechanism shall be properly sealed to prevent water intrusion into the cabinet.
- CR3-68** [65] Some customers require that exterior, removable access panels be fastened with security screws requiring the same tool as is used for the hinged door locking mechanism.
- CR3-69** [66] Some customers require the use of a special locking mechanism that is integrated into each door in lieu of the cabinet manufacturer's standard locking mechanism.

## 3.12 Alarms

### 3.12.1 General

- R3-70** [67] Intrusion, and AC power failure alarms shall be provided for remoting to an alarm monitoring center.
- CR3-71** [68] Some customers require that an audible, local intrusion alarm be provided to work in conjunction with the remote alarm. When required, a timed (as specified by the customer) reset feature shall be provided to allow the craft to temporarily inhibit the audible alarm.
- R3-72** [69] Cabinets with active cooling systems, such as forced air ventilation or other heat exchange systems, shall provide a system failure alarm for remoting to an alarm monitoring center.
- CR3-73** [70] Some customers require that a temperature sensor be located in the electronic equipment compartment to provide a high temperature alarm (customer specified) for remoting to an alarm monitoring center. (This feature may be provided by the housed equipment.)
- CR3-74** [180] Some customers require that an alarm be provided for remoting to an alarm monitoring center upon detection of failure of a battery compartment heater system.
- R3-75** [181] For cabinets using an active system (i.e., activated by the detected hydrogen concentration level) to meet the maximum hydrogen concentration requirements of **R3-130**, an alarm shall be provided for remoting to an alarm monitoring center upon detection of excess hydrogen concentration in the battery compartment. (An alarm is not required for cabinets using a passive system to meet the hydrogen concentration requirements.)
- CR3-76** [182] Upon detection of excess hydrogen concentration in the battery compartment, some customers require that the rectifier shall be shut down and latched off, and manual intervention be required to restore power.

### 3.12.2 Engine-Generator

Cabinets containing a permanent engine-generator ([Section 3.20](#)) shall provide the following additional alarms, or equivalent, for remoting to an alarm monitoring center. [Unless otherwise indicated, the term “engine generator” as used in this document refers to both engine-generators (DC output) and engine-alternators (AC

output).] The customer may modify these alarm requirements to satisfy local monitoring schemes and capabilities, or may require that additional alarms, present at the engine-generator, be remotored to the alarm monitoring center. (See Section 4.12 of TR-NWT-001293<sup>[27]</sup>.)

- R3-77** [183] *Engine Failure (Major)*: The engine-generator failed to attain proper operation or was shut down by one of its safety shutdowns.
- R3-78** [184] *Engine Failure (Minor)*: Low or high engine temperature, low engine oil, failure of battery charger, or low battery voltage.
- R3-79** [185] *Proper Operation*: Commercial power has failed and the engine-generator has started and assumed the load.
- R3-80** [186] *Load Transfer*: Commercial power has failed and the engine-generator has started but has not assumed the load.

### 3.13 Condensation

Cabinets are subject to a wide range of outdoor environmental conditions, including temperature and humidity. For cabinets containing electronic equipment, the internal power dissipation following turn-up will tend to significantly reduce the likelihood of condensation within much of the cabinet. In general, the cabinets must avoid condensation both before and after turn-up, when exposed to external ambient humidity levels in the range of 5% to 95% relative humidity.

- R3-81** [71] The manufacturer shall provide instructions and procedures to minimize the formation of condensation on installed electronic telecommunications equipment prior to turn-up, in various environments. These procedures shall be documented in the cabinet installation and maintenance practices.
- R3-82** [72] When the cabinet is in operation, condensation shall not form on, or drip onto, the electronic equipment. The manufacturer shall specify the means to accomplish this in various environments.

### 3.14 Fans

Fan manufacturers provide L-10 life ratings for their fans. The L-10 rating is an industry standard indicating that 90% of the fans in a test sample will be functional (operate at rated speed) after operating at the specified temperature for the specified number of hours.

- R3-83** [73] All cabinet fans shall have a minimum L-10 life rating of 40,000 hours at 40°C (104°F).



- O3-84** [187] It is desirable that cabinet fans shall have a minimum L-10 life rating of 80,000 hours at 40° C (104° F).
- O3-85** [188] To minimize noise, fans should be connected to a door switch that turns off non-critical fans when the cabinet doors are open.
- O3-86** [189] To allow for verification of fan operation, an override means should be provided to allow fans to operate with the doors open and regardless of temperature. The button should be clearly labeled and in an accessible location that is separate from the audible alarm inhibit button.
- R3-87** [190] Accessible fans shall be equipped with guards to prevent personal injury.

### 3.15 Bonding and Grounding

- R3-88** [74] The cabinet shall include a bonding buss bar which has the capacity to terminate a minimum of 8 ground wires, of solid or stranded 6 AWG copper, associated with internal metallic and/or fiber optic cables and external grounding to power company MultiGround Neutrals (MGNs), transformers, etc. The bonding buss bar shall accommodate ground wires terminated with dual-hole lugs.
- R3-89** [75] The bonding buss bar shall have a cross section, not including the hole area, exceeding that of 6 AWG wire and provide electrical continuity between all bonds and ground wire with a current carrying capacity equal to or exceeding that of a 6 AWG copper wire.
- R3-90** [77] The bonding arrangement shall permit the lifting of individual cable bonds, without the disturbance of other bonds, during testing activities.
- R3-91** [78] The doors of a metal cabinet shall be grounded by bonding each door to the main cabinet using a flexible copper braid or other means, such as through the door hardware, equivalent to a 6 AWG copper wire minimum. There shall be no interference with gaskets, door operation, etc. For lift-off doors, a detachable frame ground connection is required.

### 3.16 AC Power

Requirements in this section apply to cabinets housing equipment that require commercial AC power input. Typical deployed electronic cabinets are powered by an adjacent or co-located power pedestal, or by commercial power directly terminated at the cabinet.

### 3.16.1 Commercial Power

- R3-92** [79] Cabinets, served with commercial power shall accept 120/240 volt, single phase, power with an amperage service sized as required to power the electronic equipment in the cabinet.
- CR3-93** [80] Some customers specify increased amperage service to facilitate future expansion.
- R3-94** [81] Cabinets served with commercial power shall be powered using a Nationally Recognized Test Laboratory (NRTL) certified power distribution panel containing a main circuit breaker and/or individual circuit breakers of the correct size as required for the electronic equipment or as specified by the customer.
- R3-95** [82] A decal showing an electrical schematic of the AC power wiring shall be affixed to the inside surface of the cabinet.
- R3-96** [83] The service entrance connection panel for termination of the commercial AC, including overcurrent protection devices and other components individually, shall conform to requirements of the National Electrical Manufacturers Association (NEMA) and National Electrical Code (NEC) and shall be listed by an NRTL.
- R3-97** [84] A surge suppressor shall be provided to protect systems from surges in the 120/240 volt service and load center. This shall be a gapless suppressor listed by a NRTL for the purpose intended. The surge suppressor shall be placed on the main power feed to the load center.
- Note:** It is not required to have a surge suppressor if one is in a co-located cabinet and commercial AC power is not directly brought into the cabinet.
- O3-98** [85] The surge suppressor shall be selected based on the susceptibility of the equipment powered by the electrical service, with margin provided for locally generated disturbances. Reference should be made to ANSI/IEEE C62.41<sup>[28]</sup> and TR-NWT-001011<sup>[29]</sup>.
- R3-99** [86] At least one 120 volt AC, 15 amp duplex convenience outlet, capable of accommodating a transformer of dimensions 3-inches by 3-inches by 3-inches, shall be provided in the electronic equipment compartment. All convenience outlets shall be equipped with ground fault interrupter (GFI) protection.
- Note:** It is not required that the commercial AC power serving and directly connected to equipment within the cabinet be equipped with GFI protection.

- R3-100** [87] Means shall be provided to facilitate the mounting of a commercial power meter on one of the cabinet surfaces, as specified by the customer.
- R3-101** [88] Means shall be provided for routing power from the power meter base to the distribution panel or, for cabinets powered by a separate pedestal, for routing underground power to the cabinet.
- CR3-102** [191] Some customers require a cabinet option that provides for integrated power distribution, external meter mounting, generator input, and power transfer switches.

### 3.16.2 Auxiliary Power

- R3-103** [192] Cabinets containing a permanent engine-generator (DC output) for auxiliary power shall comply with Section 4.11.2 of TR-NWT-001293.
- R3-104** [193] For cabinets containing a permanent engine-alternator (AC output) for auxiliary power, an automatic power transfer switch shall be provided. This switch shall comply with Section 4.3 of TR-NWT-001293.
- R3-105** [89] For cabinets using a portable engine-alternator for auxiliary power, an NRTL listed power transfer switch and NRTL listed auxiliary generator input connector shall be provided as a cabinet component or located externally in a separate enclosure as stipulated by the customer. This connector shall comply with the customer's requirements.
- R3-106** [90] A weatherproof power transfer switch shall be utilized. It shall be rated "3R", per UL 50<sup>[30]</sup>.
- R3-107** [91] For all cabinets using commercial AC power, a portable engine-alternator, power input connector shall be provided to facilitate the connection of a portable engine-alternator at the transfer switch. This connector shall comply with the customer's requirements.
- R3-108** [92] Power transfer switches shall have a positive interlock feature so that it is not possible to have both alternative power sources on simultaneously. The supplier shall contact the customer to determine if there are any other specific requirements imposed by local electrical codes.
- CR3-109** [93] Some customers require that an indicator lamp be provided for each leg of the commercial power to indicate when commercial power is being supplied.

### 3.17 Splicing Compartment

- R3-110** [94] For cabinets containing a splicing compartment, space shall be provided for splicing and storing the splice(s) for the maximum number and sizes of feeder and distribution cables that can be accommodated by the cabinet. The cabinet shall allow for a splice closure/shelf and cables/tails to store in such a manner as to be easily removable and replaceable as new cables/tails are added. Copper cable splices shall be stored behind a shield that protects the cables and inhibits the transfer of filling compounds to other sections of the cabinet.
- R3-111** [95] The splicing compartment shall be positioned to ensure protection to the electronic equipment from filling compounds, encapsulant materials, and the environment during splicing and maintenance operations.
- CR3-112** [194] Some customers require that an appropriate hardware or container be provided to facilitate the encapsulation of splices within the splicing compartment.
- CR3-113** [96] Some customers require that the splicing compartment be accessible through a hinged outside door or a removable panel.
- R3-114** [97] A minimum of two cable access ports shall be provided in the base of the splice chamber. These ports facilitate the entrance of metallic and fiber cables -- typically, 1.3 cm to 6.4 cm (0.5 in to 2.5 in) in diameter -- through 10.2-cm (4-in) conduits. (The conduits will extend vertically out of the cabinet's concrete mounting pad.)
- R3-115** [98] The splice chamber shall allow the cabinet to be placed over the conduits (with cables in place) without the need for craft to reach under the cabinet to feed cables into the cable access ports.
- R3-116** [99] Cable entrance seals shall be provided to seal between the cables and their point of entrance into the cabinet thereby preventing water and rodent intrusion into the splice chamber.
- R3-117** [195] For cabinets terminating coaxial distribution or drop cables, tie downs shall be provided to support the coaxial cables.
- R3-118** [196] For cabinets terminating coaxial distribution cables, sufficient space shall be provided to facilitate cable preparation and termination. Termination is typically made approximately 3 feet from the cabinet mounting surface.

- R3-119** [197] For cabinets containing coaxial distribution or drop cables within the cabinet, sufficient space shall be provided to allow their proper routing and storage. Drop and distribution coaxial cables should be free of bends for a distance of 2 and 6 inches from their connectors, respectively. The bend radius for drop and distribution cables should not be less than 5 and 10 times their diameter, respectively.
- R3-120** [198] For cabinets terminating fiber cables, tie downs shall be provided to support stored fiber cables.
- CR3-121** [199] Some customers require that sufficient space be provided to store and support as much as 15.24 m (50 feet) of fiber cable while maintaining a minimum bend radius of 10 times the cable's diameter.
- R3-122** [200] For cabinets terminating fiber cables, sufficient space shall be provided to store and securely mount fiber termination apparatus.
- CR3-123** [201] Some customers require provision for the storage and secure mounting of fiber cable(s) and splicing arrangements.

### 3.18 Electronic Equipment Compartment

- R3-124** [101] The electronic equipment compartment shall be accessible through a hinged outside door.
- CR3-125** [102] Some customers request lift-off panels in lieu of hinged doors if the cabinet is to be placed in an area having restricted access.
- R3-126** [103] The electronic equipment compartment shall be cooled without the entrance of outside air.

**Note:** Small vents in the equipment compartment may be provided to control humidity and condensation by means of the gradual entrance of a small amount of outside air over an extended period.

### 3.19 Battery Compartment

Electronic equipment cabinets applications typically require an 8-hour battery reserve for "life-line" telephony services (e.g., per TA-NWT-000406<sup>[31]</sup>). However, for cabinets supported by permanent on-site auxiliary power, a reduced reserve is sufficient, such as 1 to 2 hours.

- R3-127** [104] The cabinet's maximum battery capacity (physical volume and estimated amp-hours), consistent with the hydrogen evolution rate of **R3-130**, shall be provided by the cabinet manufacturer.

- R3-128** [105] The location of the batteries shall maximize the control of their temperature and ventilation.
- R3-129** [107] Batteries shall be stored within a separate compartment sealed from the other cabinet compartments and adequately ventilated to the atmosphere outside of the cabinet.
- R3-130** [108] The battery compartment shall be vented to eliminate explosion hazards due to the release of gaseous products by the batteries. Hydrogen gas concentrations in the battery compartment or any other cabinet compartment shall not exceed 1.0% by volume. The cabinet manufacturer shall specify and verify the maximum hydrogen evolution rate that can be ventilated by the battery compartment without exceeding a maximum hydrogen concentration of 1% in the cabinet. This hydrogen evolution rate shall be compatible with the maximum number of batteries intended for use in the cabinet, which number shall be indicated by the cabinet manufacturer.
- Test Procedure - Helium (or hydrogen with appropriate safety measures) may be used to measure the performance of the battery compartment ventilation system in order to determine the maximum allowable hydrogen evolution rate. Helium sensors shall be placed in all cabinet compartments that are subject to hydrogen evolution from the battery compartment. The cabinet shall then be placed in an enclosure to prevent air movement around the cabinet during testing. Helium shall be injected into the battery compartment until a concentration of 1% is reached. The rate of helium injection required to maintain a 1% concentration under steady state conditions shall be reported. Steady state shall be defined as a maximum variation of  $\pm 0.25\%$  over a period of one hour. The test shall be performed with the cabinet stabilized at  $25^{\circ}\text{C}$  ( $77^{\circ}\text{F}$ ). For cabinets using a temperature activated heat exchanger, the heat exchanger shall not be active during this test.
- O3-131** [109] It is desirable that temperatures above  $46^{\circ}\text{C}$  ( $115^{\circ}\text{F}$ ) and below  $-10^{\circ}\text{C}$  ( $14^{\circ}\text{F}$ ) be avoided in the battery area to maximize the life and capacity of the batteries.
- R3-132** [110] Thermostatically controlled heating pads or other means shall be provided to maintain the battery temperatures above the recommended minimum temperature. The battery manufacturer shall provide the intended operating temperature range. The temperatures depend on both the battery technology deployed and the battery manufacturer. This feature shall be available as both a factory and field installed option and cabinets shall be pre-wired to support these options.

- CR3-133** [111] Some customers require that either batteries be stored in battery drawers, or batteries have front access to facilitate installation and maintenance as required.
- CR3-134** [112] Battery drawers, when provided, shall open fully allowing replacement of any battery without the need to move any other batteries in the string, and provide adequate spacing for proper ventilation between batteries over their entire length. Drawer glides shall continue to function in the event of contamination (sand, dust, etc.).
- R3-135** [113] The battery chamber shall facilitate the safe installation, inspection or replacement of the batteries in a minimum amount of time by one person. Thus, for cabinets providing a battery shelf to support front access, the shelf shall
- ... • Allow replacement of any battery without the need to move any other batteries in the string
  - ... • Provide adequate spacing for proper ventilation between batteries over their entire length
  - ... • Provide a surface for easy installation and removal of batteries
  - ... • Meet all materials requirements of this GR document, and be impervious to battery acids and “no-ox” compounds.
- CR3-136** [115] Some customers require that the battery chamber allow the visual inspection of both terminals on each battery in normal daylight without the use of mirrors, insulated hand tools or the need to disconnect the cabling harness.
- R3-137** [117] Any required ancillary cabinet apparatus which may come in contact with the battery terminals shall be insulated to prevent possible shorting.
- R3-138** [118] The battery chamber shall prevent rodent entry, minimize the penetration of insects, contaminants, and water, and prevent water from getting onto the posts of the battery. The chamber shall also allow for water drainage.

### 3.20 Engine-Generator Compartment

Cabinets may be equipped with a permanent engine-generator to provide emergency DC or AC power, or both, depending on the needs of the housed equipment. Alternatively, a separate engine-generator may be permanently located adjacent to the cabinet, or a portable engine-generator would be used as necessary.

- R3-139** [202] The engine-generator shall be located in a secure, lockable compartment within the cabinet.
- R3-140** [203] All engine-generator controls shall be located within the secured engine compartment.
- R3-141** [204] Engine-generators shall meet the general and functional requirements outlined in Sections 3 and 4 of TR-NWT-001293. The test procedures provided in Section 8 of TR-NWT-001293 shall be utilized to verify conformance.
- R3-142** [205] Engine-generators shall meet the marking, packaging, and shipping requirements outlined in Section 5 of TR-NWT-001293.
- R3-143** [206] Engine-generators shall meet the quality assurance requirements outlined in Section 6 of TR-NWT-001293.
- R3-144** [207] Engine-generators shall meet the documentation and training requirements outlined in Section 7 of TR-NWT-001293.
- R3-145** [208] Cabinet components shall minimize head losses in engine air intake and exhaust systems. Required combustion air (cubic feet per minute) and allowable exhaust system back-pressure (inches of mercury) can be provided by the engine manufacturer.
- R3-146** [209] Cabinet ports for engine air intake and exhaust shall be located above expected snow depths for the geographic area of deployment.
- R3-147** [210] Cabinet ports for engine air intake and exhaust shall be protected from water, snow, or ice blockage.
- R3-148** [211] Shutters utilized on engine air intake and exhaust ports shall be protected from freezing that will prevent or restrict their operation.
- R3-149** [212] Cabinet, engine exhaust ports shall be protected from wind-generated velocity heads that will increase exhaust back-pressure.
- R3-150** [213] The engine compartment shall allow front access to components requiring periodic service.
- R3-151** [214] The engine compartment shall be cooled to ensure that the engine-generator does not exceed its manufacturer's recommended maximum operating temperature after continuous operation for four hours under worst case conditions. Worst case conditions are defined as
- ... • Engine-generator operating at maximum output power
  - ... • Ambient temperature of 46° C (115° F)



- ...
- Cabinet exposed to maximum solar load as defined in **R3-187**.

**R3-152** [215] The temperature of the exhaust gases at all points of the exhaust stream outside the cabinet shall not exceed 200° C (392° F) at a velocity of 10 m/s<sup>[32]</sup> (33 ft/sec), in a 40° C (104° F) ambient. For velocities other than 10 m/s, and greater than 3 m/s, the temperature shall not exceed the value

$$200^{\circ} \text{ C} \times (10 / \text{air velocity})^{1/2}$$

where the air velocity is given in m/s.

### 3.21 Pole Mounted, Aerial Cabinets

**R3-153** [119] Pole mounted, aerial cabinets equipped with cable stubs shall provide mechanical strain relief to the cable stub to permit shipping, handling and hoisting of the cabinet without causing damage to the cabinet or to the stub.

**R3-154** [120] Cabinets furnished with terminated cable stubs shall have the metallic shield of the stubs bonded to the bonding buss bar with the electrical continuity of a 6 AWG copper wire minimum.

**CR3-155** [121] Some customers require that a safety strap attachment point be provided on pole mounted, aerial cabinets. This safety strap attachment point shall withstand the specified test load without permanent deformation of any cabinet components.

Test Procedure - The cabinet shall be mounted per the manufacturer's instructions and a 1.22 m (4 ft) long safety strap shall be attached to the cabinet attachment point using a snap-hook on one end of the strap. The snap-hook on the opposite end of the strap shall be attached to a 136 kg (300 lbs) weight. The weight shall be raised to the level of the safety strap attachment point and permitted to free fall for 1.22 m (4 ft).

**R3-156** [216] If required or recommended by the manufacturer to achieve greater strength or stability, the manufacturer shall provide hardware for mounting the cabinet on two adjacent poles and shall include detailed procedures for proper installation.

### 3.22 Documentation

**R3-157** [123] A complete set of documentation shall be provided with the cabinet to facilitate proper installation and maintenance. The following topics shall be covered. Additional topics may be required by the customer.

- ... • List of tools and equipment required for installation
- ... • Safety procedures to be followed
- ... • Site preparation details
- ... • Concrete pad construction details
- ... • Cabinet placement and mounting details
- ... • Electrical schematic of cabinet including location of alarm access points
- ... • Installation, maintenance and repair procedures
- ... • Cabinet manufacturer's telephone number for technical assistance and ordering of parts
- ... • Installation, maintenance and repair procedures for field installable or replaceable parts or equipment.

**R3-158** [124] Suppliers of cabinets with installed telecommunications equipment shall provide decal(s) on the inside doors of the cabinets containing information on the equipment system, internal cabling, powering schematics, etc., and shall provide space for recording other data per the customer's instructions.

**CR3-159** [125] Some customers require the manufacturer to prepare training packages, that may include audio-visual presentations, for the purpose of training craftpersons in the placement and use of the cabinet. Training requirements are addressed in GR-839-CORE<sup>[33]</sup>. The manufacturer should contact the customer for specific requirements.

### 3.23 Marking, Packaging, and Shipping

**R3-160** [126] The cabinet and its shipping container shall be readily identifiable and marked with the manufacturer, model number, date of manufacture (month and year), serial number and approximate gross weight.

**R3-161** [127] All shipping container and pallet markings shall be a minimum of 1.9 cm (3/4 in) in height.

**R3-162** [128] A shipping container shall be provided to protect the cabinet and associated components from damage during shipping and handling. Small components, e.g., screws, nuts, etc., shall be packaged in transparent sealed packages.

**R3-163** [129] The packaging shall be adequate and the cabinet cushioned, blocked, braced and anchored as necessary to prevent movement

and to ensure that no damage will occur to the unit under normal handling and shipping conditions from the manufacturer to the final installation site.

- R3-164** [130] During shipment and any subsequent outdoor storage or preinstallation period, the manufacturer shall provide materials and methods to ensure that the cabinet and its contents are protected from moisture damage, for a minimum of 2 months.
- R3-165** [131] The shipping pallet shall be constructed to allow the cabinet to be moved by a forklift from the ends, or the sides, as required. The length of forks required for safe lifting shall be clearly marked. If the pallet cannot be lifted from a particular end or side, that surface shall be clearly marked to alert the fork lift operator.
- R3-166** [132] The shipping pallet shall withstand the abuse of shipping and handling and minimize splintering of its components.
- R3-167** [133] Non-metallic tie-down straps shall be used to avoid possible damage to the cabinet during shipping and handling.

### 3.24 Installation and Maintenance

- R3-168** [134] Properly sized, corrosion resistant hardware (bolts, washers and lockwashers), per **R3-11** and **R3-12**, shall be provided to permit proper installation of the cabinet.
- R3-169** [135] Corrosion resistant shims (per **R3-11** and **R3-12**), as required, shall be provided to insure proper installation of the cabinet and to facilitate door alignment per the manufacturer's instructions.
- R3-170** [217] Pad mounted cabinets requiring leveling or alignment to ensure proper operation shall not require external means of lifting to be leveled. The means for leveling the cabinet shall be integrated into the cabinet, not interfere with shim placement, and be able to be withdrawn or retracted after shims are supporting the cabinet.
- R3-171** [136] Corrosion resistant inserts, per **R3-11** and **R3-12**, shall be provided for pad mounting brackets or frames to eliminate the potential for any corrosion of the cabinet after being installed on the pad.
- R3-172** [137] The manufacturer shall make replacement parts available for a minimum of 10 years from the date of manufacture.
- R3-173** [138] The manufacturer shall identify all components of the cabinet that may require maintenance (monthly, yearly, etc.).

- R3-174** [139] Ordering information shall be provided for parts that may require replacement.
- O3-175** [140] Replacement parts should be obtainable through a local distributor and the manufacturer. Supplier shall list all parts that are available locally, and shall list all parts that are only available from the supplier.
- O3-176** [141] Equivalent parts information should be provided for those parts that can be obtained from other manufacturers. Supplier shall list all parts that are available locally, and shall list all parts that are only available from the supplier.
- R3-177** [142] Complete cabinet installation instructions shall be provided as stated in [Section 3.22](#). It should be assumed that the pad, cable entrance conduits and possibly the cables will be in place prior to cabinet installation.
- R3-178** [143] A pad for cabinet mounting shall be made of precast or cast-in-place reinforced concrete or other suitable prefabricated material. Any brackets, inserts for fastening, conduit openings, gaskets or other items necessary for cabinet mounting or pad construction shall be identified by the manufacturer in a detailed pad drawing(s) covering all sizes of pads that could be installed.
- CR3-179** [144] Some customers require that the pad drawing include information for mounting a commercial power pedestal (specified by customer).
- R3-180** [145] The manufacturer shall provide a template for locating inserts, conduit openings or slots for cast-in-place concrete pad construction.
- R3-181** [146] The manufacturer shall supply pad installation instructions pertaining to pad bearing surface, compaction, levelness and elevation relative to final grade, and should note that conduit for cable placing and necessary grounding devices must be installed prior to placement of the cabinet mounting pad.
- R3-182** [147] For concrete pad mounted cabinets having an aluminum mounting surface, the manufacturer shall provide a non-metallic gasket for use between the concrete pad and the cabinet mounting surfaces to eliminate the potential for chemical corrosive action. Caulking compounds are not to be used at this interface.

- O3-183** [218] A non-metallic gasket should be used on cabinets having steel mounting surfaces to prevent corrosion in case paint is scraped off the cabinet surface.
- CR3-184** [148] Some customers require that the pad extend 61 cm (2 ft) beyond the opened doors of the cabinet to allow for additional working space in and around the cabinet.

### 3.25 Quality

- R3-185** [149] The manufacturing processes, test and inspection procedures, and quality program used by a manufacturer shall be adequate to assure that technical requirements and customer end-point requirements are met. Quality Assurance criteria in this area cover, for example, the ability of the factory testing program to assure product operability and functionality. Recommended quality program criteria are documented in GR-1252-CORE<sup>[34]</sup>.
- R3-186** [150] The supplier shall, upon request, allow the customer or its representative to verify the ongoing quality and reliability of the product by means of an on-site quality surveillance program. Details of this program are normally addressed during contract negotiations.

### 3.26 Exposure to High Temperature

Thermal stress is a major contributor to equipment malfunctions, reduced long-term reliability and component failure. Thermal conditions are dependent upon the conditions both outside and inside the cabinet. Thus, the ambient temperature, solar loading, and equipment power dissipation, including that associated with a possible engine-generator (Section 3.20), are critical factors. In addition, external and internal conductive, convective and radiative thermal paths have significant effects on the temperature of housed equipment, circuit packs and individual components. The presence and operation of the housed equipment changes internal and external thermal paths and thermal gradients within the cabinet. Therefore, thermal tests must be performed on fully equipped operational cabinets, representative of that provided by the supplier and deployed by the customer. During these high temperature thermal tests, the temperatures of key thermal locations, on or within housed equipment or circuit packs, are measured and confirmed to be within the manufacturer's acceptable limits to ensure proper equipment functionality and reliable operation.

Solar energy incident upon and absorbed by the cabinet (Solar Load) can equal or exceed the power dissipated by the equipment operating within the cabinet. The Solar Load anticipated in field applications depends upon many variables. Simulation of the full range of field variables is beyond the scope of this document.

Therefore, the objective of the present test procedure(s) is to provide practical, repeatable means of determining and applying the Solar Load, and which can reasonably account for cabinet design variations (e.g., materials, shape, cooling method, etc.).

Depending upon the type of cabinet construction and configuration, two different methods of applying the Solar Load are specified. For Category 1, comprising electronic equipment cabinets of primarily metal fabrication of relatively simple geometry, employing forced air convection within the cabinet to accomplish cooling, strip heaters shall be used to apply the Solar Load. For the other cases (Category 2), such as those including cabinets fabricated using a significant amount (more than 20% of the surface area) of non-metallic materials for exposed surfaces, whose surface contours and protrusions (e.g., cooling fins) increase the total cabinet surface area by more than 15% over the basic geometric area, or which do not use forced convection within the cabinet to accomplish cooling, solar simulators shall be used to apply the Solar Load. In order to maintain accuracy and repeatability, strip heaters and solar simulators shall only be applied to their respective categories, as indicated, and not to the other category of cabinet design.

- R3-187** [152] The cabinet supplier shall identify the critical thermal locations and their associated maximum allowable temperatures, for all originally supplied equipment, and for all equipment manufacturers, in the corresponding cabinet configuration. The housed equipment, circuit packs and individual components identified shall not exceed their specified maximum operating temperatures when the cabinet is subjected to an ambient temperature of 46° C (115° F) and maximum solar load using the stated test procedure below. The presence, location, and details of fans or other cooling components, such as heat exchangers, shall be noted, as well as the presence of an engine-generator within the cabinet. A detailed description of the test procedure, including all relevant calculations and assumptions, shall also be provided.

Test Procedure -

A. Electronic Equipment

The cabinet shall be fully equipped and populated with the equipment and circuit packs corresponding to the tested model number. For a given cabinet model number, the model and vintage circuit packs selected shall be those corresponding to the maximum heat dissipation rate within the cabinet, consistent with the cabinet specifications and usage.

The cabinet supplier shall provide the following information for all housed equipment:

- ... • Identification, manufacturer, and model number and vintage of equipment shelves and circuit packs
- ... • Location in cabinet during testing

- ...
- Heat dissipation when operating at maximum output
- ...
- Sensitivity to condensation or environmental contaminants
- ...
- Schematic of operational cabinet
- ...
- Detailed operating procedures to be followed during testing.

#### B. Cabinet Mounting

The cabinet shall be mounted to simulate the worst case heat transfer mounting conditions expected in use. For example, if a pole-mounted cabinet can be mounted on either a wooden or metal pole, the wooden pole shall be used in the test because of its lower thermal conductivity. For a ground mounted cabinet, the test floor shall not provide greater thermal conductivity than the expected mounting pad. If the test is to be conducted in a chamber with a metal floor, insulation, such as plywood, may be required to minimize heat transfer from the cabinet to the floor.

#### C. Simulation of High Ambient Temperature

Testing shall be performed in a room or chamber where the temperature is allowed to stabilize at or below 46° C (115° F). To prevent the ambient temperature from exceeding 46° C (115° F) for high power cabinets, it may be necessary to cool the room or chamber walls and/or ceiling (for example, with a wind shielding room built within a temperature controlled room or chamber). Temperatures provided by sensors located within the cabinet and at key components and locations shall be adjusted to reflect the difference between the ambient room temperature and 46° C (115° F). For example, for a room temperature of 22° C (72° F) all internal measured temperatures would be increased by 24° C (43° F) to obtain the temperature to be reported. The room ambient temperature shall be measured at a minimum distance of 1 m (3 ft) horizontally from the cabinet and vertically, at the mid point of the cabinet above the room or chamber floor. The ambient temperature sensor shall be shielded from, or placed to avoid, local temperature effects such as those induced by radiation or forced air flow from the cabinet or test equipment.

#### D. Presence of Wind

The presence of wind, which is likely in many geographic locations, can result in lower internal cabinet temperatures. However, to avoid an uncontrolled variable and the associated loss of accuracy and repeatability, the test cabinet shall not be subjected to wind generated by the test environment (e.g. air conditioning, fans, open doors, test equipment cooling, etc.). Thus, the cabinet shall be located such that maximum measured air speed is 0.1 m/sec (0.25 mph), when measured at any point 1 m (3 ft) from the outer cabinet

surface. The maximum air speed at this distance shall be recorded and reported.

**Note:** Because wind may be created by the cabinet's normal operation (e.g., cooling methods), it may be necessary to check for excessive air movement or wind after the test environment is established, but before the cabinet is activated. If an engine-generator is contained within the cabinet, in order to maintain a safe test environment, it may be necessary to directly vent the exhaust gases to the outdoors to reduce or eliminate the need for ventilation that may create significant wind within the test area.

#### E. Solar Absorptance

The Sun's rays (solar flux) are partially reflected and partially absorbed by the cabinet. The amount of heat absorbed is dependent on the solar absorptance value(s) of the cabinet surfaces. Solar absorptance is related to cabinet color, gloss, texture, cleanliness, etc. Appropriate initial values of solar absorptance, **A0**, shall be provided by the suppliers of the cabinet finish. Absorptance values typically increase as the cabinet surface and finish ages, and such aged values, **A1**, should also be provided by the suppliers of the cabinet finish. In the absence of the latter information, the aged value for the solar absorptance, **A1**, shall be assumed to be that given by the heuristic relation  $(1 + 3 \times A0)/4$ . Since it is recognized that in some cases (e.g., for surfaces with a relatively high value of **A0**) the actual aged value for the solar absorptance may be lower than the initial value, for the present purposes, the effective absorptance **Ae** shall be assumed to be the larger of **A0** and **A1**. This procedure shall be applied to determine the effective absorptance value for each cabinet surface (or subsection), since the cabinet may possibly include different colors and absorptance values. The cabinet supplier shall provide the corresponding **A0**, **A1**, and **Ae** information and support data.

#### F. Application of Solar Load

The direct incident solar flux is considered to be that due to a total short wave radiation intensity of  $753 \text{ W/m}^2$  ( $70 \text{ W/ft}^2$ ) applied to 100% of the top surface area, and 50% of the total vertical (lateral) surface area. (This solar flux level is intended to account for the additional indirect radiation received by the cabinet due to the effects of diffuse and reflected radiation.) This procedure may be applied to cabinets of basically rectangular geometry, or to cabinets with vertical sides comprised of curved walls or with curved or contoured upper (top) surfaces. (For a more complex cabinet geometry, such as a conical or pyramid shape enclosure, the entire surface area shall be assumed to be subject to the indicated incident solar flux, unless the supplier can demonstrate that a reduced area and/or flux level is appropriate.) For the purpose of identifying or



determining the energy absorbing surfaces and areas, only the gross surface contour characteristics need be considered; i.e., local irregularities or features (e.g., ribs, cooling fins, door hardware, or other distinctive surface characteristics) may be ignored.

The lateral area heated shall be contiguous. The lateral surfaces heated shall be chosen to cause the worst case temperature rise within the cabinet, considering both the cabinet design and the location of equipment within the cabinet.

1. *Category 1 Cabinets - Strip Heaters*

Strip heaters shall be used to apply the absorbed Solar Loads to the cabinet top and relevant vertical (lateral) surface areas. The corresponding absorbed Solar Loads are determined by multiplying the incident solar flux for each specified surface (or subsection) by its effective solar absorptance value,  $A_e$ .

Example: Consider a cabinet of rectangular geometry, 60 inches high, 48 inches long (front/rear), and 24 inches wide (left/right sides). Assume the top surface (48 in x 24 in) has an initial absorptance value ( $A_0$ ) of 0.7, the front and rear surfaces (60 in x 48 in) an initial absorptance value of 0.5, and the sides (60 in x 24 in) an initial absorptance value of 0.6. The corresponding effective (aged) absorptance values,  $A_e$  (equal  $A_1$  in this example), are selected to be

$$\text{top: } (1 + 3 \times 0.7)/4 = 0.775$$

$$\text{front/rear: } (1 + 3 \times 0.5)/4 = 0.625$$

$$\text{sides: } (1 + 3 \times 0.6)/4 = 0.7$$

The absorbed Solar Load on each relevant surface is then calculated as

$$70 \text{ watts/ft}^2 \times (4 \text{ ft} \times 2 \text{ ft}) \times 0.775 = 434 \text{ watts (top)}$$

$$70 \text{ watts/ft}^2 \times (5 \text{ ft} \times 4 \text{ ft}) \times 0.625 = 875 \text{ watts (front/rear)}$$

$$70 \text{ watts/ft}^2 \times (5 \text{ ft} \times 2 \text{ ft}) \times 0.7 = 490 \text{ watts (side)}$$

Note that for this example, the appropriate vertical surfaces correspond to the front (or rear) surface plus one side.

The strip heaters shall be selected, located and installed so as to maximize heat conducted to the cabinet surface, minimize heat lost to the surrounding environment, and minimize interference with the cabinet's cooling methods. (As a guideline, the heaters should be uniformly distributed, located a maximum of 12 inches apart and cover less than 10% of the surface.) For each relevant surface, the variability of the dissipated power density (watts per inch) between individual strips shall not vary by greater than +/- 10% of the average power density of the heaters applied to that surface when stabilized at operating power and temperature. The total power applied to each surface shall be a minimum of

the calculated absorbed Solar Load. Strip heaters shall be operated at a maximum of 75% of their rated value and at a maximum dissipated power density of  $1.2 \text{ W/cm}^2$  ( $7.5 \text{ W/in}^2$ ) with respect to the cabinet surface area with which they are directly in contact. The cabinet supplier shall provide details of strip heater locations, applied power, and mounting methods, including method of adhesion to the cabinet surface.

### 2. Category 2 Cabinets - Solar Simulators

One or more full-spectrum solar simulators shall be used to illuminate the cabinet top and relevant vertical (lateral) surface areas. In order to simulate the effect of an aged surface, the absorptance of the illuminated surfaces shall be modified to be equivalent to the effective absorptance  $A_e$ , or greater. Alternatively, the average intensity of the simulated solar flux upon each illuminated surface of the cabinet may be modified to be a minimum of  $753 \text{ W/m}^2$  ( $70 \text{ W/ft}^2$ ) multiplied by the Absorptance Aging Ratio,  $A_e/A_0$ . (See example above for calculating the aged and effective absorptance values,  $A_1$  and  $A_e$ .) The Absorptance Aging Ratio may be calculated and applied on a surface by surface basis, or a weighted average for a particular surface of several subsections may be calculated and applied to each relevant illuminated surface.

The intensity shall be measured normal to the gross surface contour illuminated, at a minimum of six points per surface. (As a guideline, the points should be located on a rectangular grid with a maximum grid spacing of 12.0 in.) The intensity of the simulated solar flux shall not be lower than the average intensity by greater than 15%. The simulated solar flux at one or more points may be greater than the average intensity by more than 15%; however, the intensity value used in calculating the average intensity shall be limited to 15%. Measured solar flux intensity shall include both direct radiation from the solar simulator and that reflected from the test enclosure. Reflectors and other devices may be used to adjust the intensity incident upon the cabinet surface. Care should be taken to minimize long-wave infra-red radiation emitted by the test enclosure, the solar simulator(s) and any devices in the test environment.



The solar simulator shall provide a spectral distribution that reasonably duplicates that of natural sunlight, as indicated in Table 1.

... **Table 1.** Spectral Distribution of Solar Simulator

Spectral Region	Wavelength (nm)	Percentage of Total Spectrum (lower limit)	Percentage of Total Spectrum (upper limit)
Ultra-violet A	280 - 320	0.0%	0.6%
Ultra-violet B	320 - 400	4.0%	7.0%
Visible	400 - 780	45.0%	55.0%
Near Infrared	780 - 3000	35.0%	53.0%

Solar flux intensity and spectral distribution shall be checked as recommended by the solar simulator's manufacturer, but not less frequently than every 500 hours of operation or 6 calendar months, whichever occurs first. Instrumentation used to measure the solar flux intensity shall be accurate to within +/- 10 W/m<sup>2</sup> (1 W/ft<sup>2</sup>) over the spectral region between 280 and 3000 nanometers. Instrumentation used to measure the spectral distribution shall be accurate to within +/- 5% of reading.

**G. Allowance for Indoor Testing**

In contrast to indoor cabinet testing, outdoor installations may benefit from the presence of wind and radiation to a sky colder than the indoor test environment. Therefore, for cabinets that are to be deployed exposed to wind and sky, after making the adjustment of paragraph C above, the test temperatures may be reduced by 4° C (7° F).

**H. Equipment Test Usage Parameters**

The cabinet shall be fully equipped and populated with the equipment and circuit packs corresponding to the tested model number. All feeder and support lines and equipment serving the cabinet operation shall be active. The activity of all subscriber services (e.g., POTS<sup>1</sup> and Digital Loop Carrier services, including Integrated Service Digital Network lines) shall correspond to 6 CCS traffic rate, or 17% subscriber usage, uniformly distributed across the equipment. Broadband or Digital Subscriber Lines (excluding High bit-rate DSL) shall be at 50% subscriber usage, and T1 (and High bit-rate DSL) lines shall be at 100% subscriber usage. The prescribed

---

1. Plain Old Telephone Service

activity may be simulated by appropriate (electrical) termination of the lines.

If an engine-generator is contained within the cabinet, it shall be operational throughout the entire test, with the commercial AC power disconnected.

I. Test Completion Conditions

The test shall be conducted until steady state conditions are achieved. Steady state conditions are defined as a maximum variation in internal and ambient temperatures of 1° C (2° F) over a one hour period.

- CR3-188** [219] Some customers require that, when applying the test procedures described in **R3-187**, the temperature measured in the hottest air spaces between the equipment and the cabinet interior surfaces be limited to a maximum of 65° C (149° F).
- CR3-189** [153] Some customers require that the cabinet be tested to **R3-187** without the application of solar loading for cabinet applications where direct exposure to sunlight will not be encountered.
- CR3-190** [154] Some customers require that the cabinet manufacturer provide information regarding the rate of temperature rise -- under the solar conditions, loads, and conditions as specified in **R3-187** -- in the event that the cabinet active cooling system becomes disabled.

Test Procedure - The procedure outlined in **R3-187** shall be followed. After temperature stabilization is achieved, the active cooling system (e.g., fans) shall be partially or totally (as specified by customer) disconnected and the internal cabinet temperature plotted versus time until maximum or new steady state conditions, or allowable component or location temperatures, are reached.

### 3.27 Thermal Shock

- R3-191** [155] The mechanical features of a test cabinet, e.g., door hinges, restrainers and bracket/shelf fastenings, etc., shall continue to function properly after a 144 hour exposure to a thermal cycle test.

Test Procedure - A cabinet shall be placed in an environmental test chamber and subjected to nine, sixteen hour cycles from 21° C (70° F) to 60° C (140° F) to -40° C (-40° F) and return to 21° C (70° F), as indicated in **Figure 3-2**. Each temperature extreme shall be maintained for a period of 4 hours and changes between temperature extremes shall be accomplished in 4 hours. After 72 hours, while the test chamber is at room temperature, the cabinet doors shall be opened and closed using normal procedures 20 times.

The cabinet shall be removed from the test chamber at the conclusion of the test period and, after stabilizing at room temperature, shall be rechecked for any deterioration of the following materials and/or mechanical features :

- ... • Gaskets/seals (physical)
- ... • Gasket/seal adhesive
- ... • Gasket/seal alignment
- ... • Gasket/seal shifting
- ... • Door hinge operation
- ... • Door locking mechanism
- ... • Door handle operation
- ... • Door alignment
- ... • Cabinet panel seam distortion
- ... • Louver panel distortion
- ... • Door restrainer operations
- ... • External condition of overall cabinet.

### Temperature vs. Time

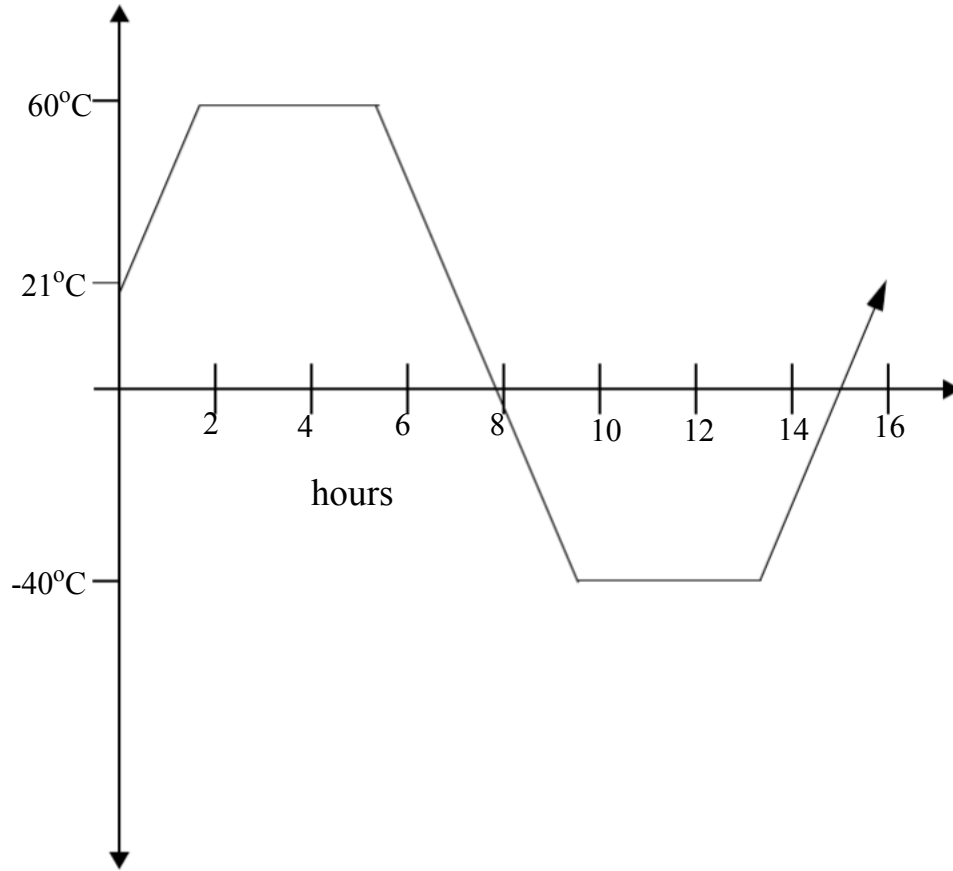

**Figure 3-2.** Temperature Cycle - Thermal Shock

### 3.28 Water and Dust Intrusion

#### 3.28.1 Wind Driven Rain

**CR3-192** [156] Some customers require that the cabinet prevent water intrusion after exposure to a simulated wind driven rain test. This test shall be conducted on the same cabinet used for the Thermal Shock test (**R3-191**) and shall be conducted immediately following that test. There shall be no evidence indicating that water may come in contact with the cabinet electronics. The maximum total accumulation of water in the cabinet shall not exceed  $1 \text{ cm}^3$  (1 gram of water) per  $0.028 \text{ m}^3$  ( $1 \text{ ft}^3$ ) of cabinet volume.

**Note:** This requirement does not apply to the battery compartment. For the battery compartment, **R3-138** applies.

Test Procedure - This test shall be performed in accordance with MIL-STD-810E<sup>[35]</sup>, Method 506.3, Procedure 1, using the following test parameters:

- ... • All fans shall be in operation and any dampers shall be open
- ... • Rainfall Rate - 15 cm/hr (5.8 in/hr)
- ... • Wind Velocity - 31 m/sec (70 mph)
- ... • Cabinet volume shall be based on overall outside dimensions.

The simulated wind shall be directed horizontally to blow through the water spray and drive it against the surfaces of the cabinet. The cabinet shall be rotated so that each surface is exposed for 30 minutes. The doors shall then be opened, one at a time, and the interior shall be examined.

#### 3.28.2 Rain Intrusion

**R3-193** [159] Cabinets shall be protected against water intrusion during heavy rain storms. The cabinet shall include provisions such that water on cabinet surfaces and doors is properly channeled or drained to prevent water running into the cabinet interior when doors are opened following the rain storm. After exposure to a simulated rain test, there shall be no evidence indicating that water may come in contact with the cabinet electronics. The maximum

total accumulation of water in the cabinet shall not exceed  $1 \text{ cm}^3$  (1 gram of water) per  $0.028 \text{ m}^3$  ( $1 \text{ ft}^3$ ) of cabinet volume.

**Note:** This requirement does not apply to the battery compartment. For the battery compartment, **R3-138** applies.

Test Procedures - The cabinet shall be mounted at the maximum allowable off-level angle per the manufacturer's recommended installation instructions, with the lower end tilted towards a side with door(s), if present. For test (a), the cabinet shall be tilted in the length-wise direction, and for test (b), in the width-wise direction. (If such maximum allowable tilt angles are not specified, a minimum angle corresponding to 1 inch per 5 feet shall be used.) All cabinet fans and other cooling systems shall be in operation during these tests and any dampers shall be open. Spray head piping as described in UL 497, Figure 20.1 shall be utilized. The central spray head shall be positioned 1.8 m (6 ft) from the point of contact and the pressure at each spray head shall be maintained at 207 kPa (30 psi).

- ... a. All doors shall be opened and closed three times prior to beginning this test procedure. The water spray heads shall be positioned to spray water perpendicular to the top surface of the cabinet. After one hour of exposure, the doors shall be opened, one at a time, and the interior shall be examined.
- ... b. All doors shall be opened and closed ten times prior to beginning this test procedure. The water spray heads shall be positioned so that water contacts all seams, door openings, hinges, handles, locking mechanisms, louvers, etc. on all sides of the cabinet. The direction of the spray shall be downward at an angle of 45 degrees from the horizontal. Each side of the cabinet shall be sprayed for 15 minutes. The doors shall then be opened, one at a time, and the interior shall be examined.

### 3.28.3 Lawn Sprinklers

- O3-194** [220] Cabinets should prevent water intrusion after exposure to a simulated lawn sprinkler test. There shall be no evidence indicating that water may come in contact with the cabinet electronics. The maximum total accumulation of water in the cabinet shall not



exceed 1 cm<sup>3</sup> (1 gram of water) per 0.028 m<sup>3</sup> (1 ft<sup>3</sup>) of cabinet volume.

**Note:** This requirement does not apply to the battery compartment. For the battery compartment, **R3-138** applies.

Test Procedure - The procedure outlined in **R3-193**, part b, should be followed, but the direction of the spray should be upward at an angle of 45 degrees from the horizontal.

### 3.28.4 Weathertightness

**R3-195** [158] Cabinets shall be made weathertight, with appropriate seals of rubber or other polymeric type materials on door edges, around door hinges, door handles, door locks and other potential openings to exclude wind driven dust or snow. Cabinets shall be exposed to wind driven dust. Dust accumulations indicated by any of the dust collectors shall not exceed that of sample 2 of the Observational Standard for Evaluating Dust Accumulation, Appendix A. (For the battery compartment, the dust accumulations shall not exceed that of sample 6.)

Test Procedure - The test cabinet shall be prepared and tested as follows:

- ... • All cabinet fans and other cooling systems shall be in operation during these tests and any dampers shall be open.
- ... • Appropriate respiration protection shall be used.
- ... • Cabinet doors shall be opened and closed 50 times prior to exposure.
- ... • Dust collectors shall be located in the horizontal plane immediately inside the cabinet at all locations where dust entry is possible; e.g., immediately inside cabinet doors at each side and at the mid-point, and at any vents. (For the battery compartment, the dust collectors shall be placed on top of the batteries.)
- ... • The dust collectors shall consist of 1.3 cm (½ in) thick, 2.5 cm x 2.5 cm (1 in x 1 in) black conductive foam pads. These pads can be made from black, conductive, high density, polyurethane foam sheet, Part No. W2754, available from Wescorp (415-969-7717), 144 South Whisman Road, Mountain View, CA 94041 or equivalent.
- ... • The cabinet shall be centrally located in an enclosure of sufficient size to provide a minimum of 46 cm (18 in) of clearance on all sides of the cabinet. The enclosure shall be sufficiently tight to contain the injected dust cloud. A minimum

of 0.9 kg (2 lbs) of 325 mesh white hydrated alumina silicate, or equivalent, shall be blown into the enclosure at an entrance velocity of 27 m/sec (60 mph) minimum. The dust shall be blown against the front or rear cabinet door, and against an adjacent side of the cabinet containing vents. The dust shall be blown against the door and side with the most apparent vulnerability to dust penetration. Half of the dust shall impact the center of the cabinet door (not directly on the gasketed area), allowing the cabinet surface to disperse the dust, and half shall impact the cabinet side (not directly on the vented area). For cabinets constructed without vents on any adjacent side, the full quantity of dust shall be blown against the door with the most apparent vulnerability to dust penetration.

- ... • After one hour of settling, the dust collectors shall be retrieved and placed in a closed box to protect them from loss of collected dust.
- ... • The dust collectors shall be visually compared to the Observational Standard for Evaluating Dust Accumulation, Appendix A.
- ... • The test shall then be repeated with all cabinet fans and other cooling systems not in operation; any dampers shall be open, if appropriate under such non-operational conditions.

### 3.29 Acoustical Noise Suppression

**R3-196** [157] Cabinets, equipped with telecommunications equipment and associated cooling fans, shall suppress acoustical noise to a level of less than 65 dBA at a distance of 1.5 m (5 ft) from the cabinet with the doors closed during times of maximum noise generation within the cabinet.

**Note:** For cabinets with a permanent generator, this criterion shall be met with the generator not running. With the generator running, the acoustical noise level shall be less than 75 dBA.

**Test Procedure -** The sound level shall be measured by a sound level meter meeting ANSI 1.4<sup>[36]</sup>, and set to the A-weighting scale and the slow meter response setting. Measurements shall be made in accordance with ANSI 1.18<sup>[37]</sup>. For the duration of this test, all equipment fans and any other noise producing equipment shall be operating so that the maximum noise possible is being produced within the cabinet. Cabinet doors shall be closed. Sound levels thus produced shall be measured at 1.5 m (5 ft) from the cabinet surfaces in all horizontal directions at a height of 1 m (3 ft) from the cabinet mounting surface. The background noise must be at least 10 dBA below the measured noise.

### 3.30 Wind Resistance

Depending upon the geographic location of a cabinet, exposure to high wind speed wind gusts is often a threat. It is important that cabinets are capable of withstanding these wind gusts without failure. Although actual wind speeds will depend upon the terrain, local topography, and height above ground level, ANSI/ASCE 7-95<sup>[38]</sup> indicates that wind gusts of approximately 67 m/sec (150 mph) may be anticipated at a 50-year recurrence interval (annual probability of 0.02) for some parts of the United States.

**R3-197** [122] Unbalanced forces may be applied to pole or wall mounted cabinets resulting in a turning moment. Such unbalanced forces may result from a non-uniform wind pressure due to partial sheltering effects. Pole or wall-mounted cabinets shall be capable of resisting the turning moment resulting from a 67 m/sec (150 mph) wind gust acting on half of the front or rear cabinet surface, without damage to the mounting hardware.

Test Procedure - A pole (single or two-pole mount) or wall mounted cabinet, mounted per the manufacturer's recommended installation instructions, shall be subjected to a force **P**, applied by means of an adapter bracket, as necessary, as shown in [Figure 3-3](#). The force shall be applied in both the forward and opposite direction, in turn. For this purpose, the cabinet shall include all equipment, including that placed after installation (e.g., batteries, circuit packs, etc.). The force shall be applied by means of a tensioning device (e.g., winch coupled with a force meter) and shall be maintained for a minimum of five seconds, in each direction. The time to fully achieve the peak force **P** shall not be less than 30 seconds.

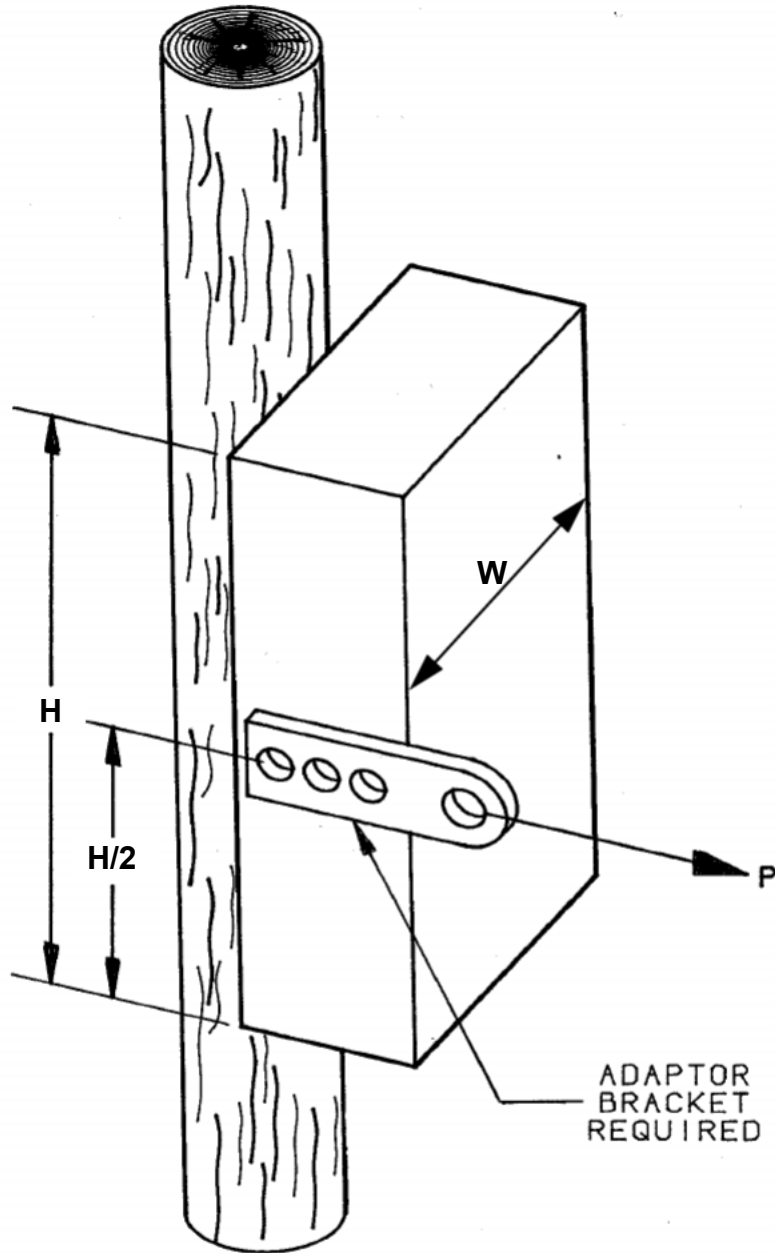

**Figure 3-3.** Application of Force to Pole Mounted Cabinet

The force **P** is calculated as follows:

$$\mathbf{P} = 0.10 \mathbf{WH}$$

where

**P** = force, lbs

**W** = cabinet width, inches

**H** = cabinet height, inches.

In no case shall the applied force be less than 100 pounds.

**R3-198** [160] Pad mounted cabinets shall be capable of resisting the overturning moment resulting from a wind gust of 67 m/sec (150 mph) perpendicular to the largest vertical surface area, without damage to the base or mounting hardware.

Test procedure - A cabinet, mounted per the manufacturer's recommended installation instructions, shall be subjected to an overturning moment, **m**, by the application of a horizontal force, **P**, perpendicular to the cabinet's largest vertical surface, as shown in [Figure 3-4](#). The force shall be applied in both the front and rear directions, in turn. For this purpose, the cabinet shall only include the equipment present at time of initial installation (i.e., excluding batteries, circuit packs, etc.) The force shall be applied at a height, **Y**, 6 inches below the top of the cabinet (or at any convenient height) by means of a tensioning device (e.g., winch coupled with a force meter) and shall be maintained for a minimum of five seconds, in each direction. The time to fully achieve the peak force **P** shall not be less than 30 seconds.

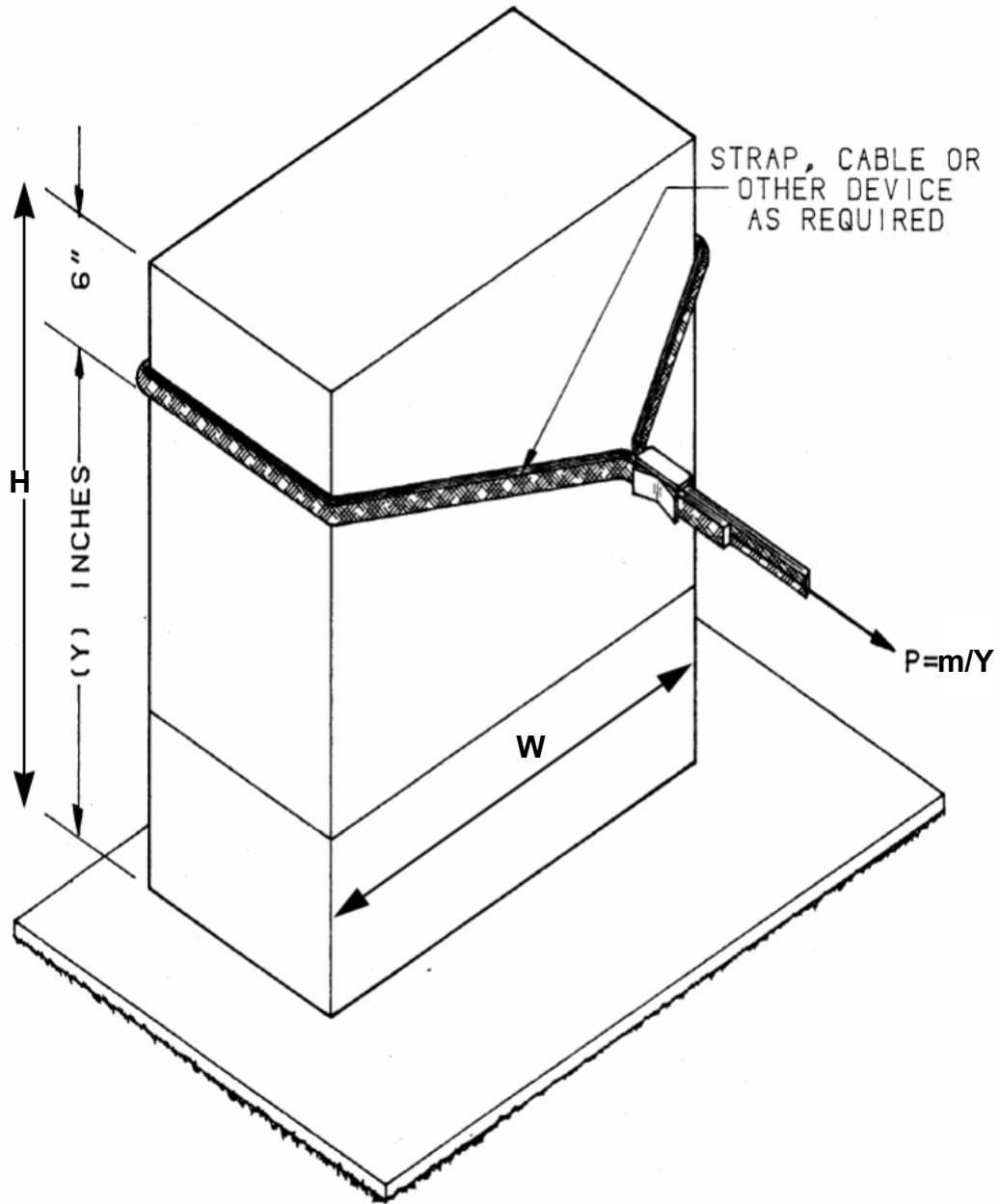

**Figure 3-4.** Overturning Moment Applied to Pad Mounted Cabinet

The force **P** is calculated as follows:

$$P = m/Y$$

and

$$m = 0.20 WH^2$$

where

**P** = force, lbs

**m** = overturning moment, inch-pounds

**W** = cabinet width, inches

**H** = cabinet height, inches

**Y** = height of applied force **P**, inches.

In no case shall the applied moment, **m**, be less than 200 x **H** inch-pounds.

### 3.31 Impact Resistance

**R3-199** [161] The cabinet shall not exhibit any fractures, mechanical damage, or impairment regarding the functioning of hinges, latches, locks, shelving, heat exchanger, etc., when subjected to the required impact loads.

Test Procedure - The cabinet shall be subjected to an impact of 100 ft-lbs delivered to each of the unique vertical and top surfaces. In the case of circular cabinets, the impact shall be delivered 180° apart and shall also include the top surface. A 7.3 kg (16 lbs), 21.6 cm (8-1/2 in) diameter, hard rubber ball shall be used to apply the impact. The roof of the cabinet shall be impacted by dropping the ball from a height of 1.9 m (6-1/4 ft) from the roof surface. For the vertical surfaces, the ball shall be suspended from a line to form a pendulum [approximately 2.4 m (8 ft) from center of ball to pivot point]. The pendulum shall be positioned so that the ball rests against the vertical wall when the pendulum is at rest. The ball shall then be pivoted until it is raised 1.9 m (6-1/4 ft) vertically from its position at rest and then released.

Metallic surfaces of cabinets shall be tested at room temperature. Cabinets with non-metallic surfaces shall be conditioned for a minimum of 8 hours at -29° C (-20° F) in an environmental chamber prior to testing. The cabinet shall then be removed and the non-metallic surfaces tested at room temperature within 10 minutes after removal. Non-metallic surfaces shall also be tested following conditioning for a minimum of 8 hours at 65° C (149° F).

### 3.32 Firearms Resistance

**R3-200** [162] Cabinets shall be capable of withstanding a 12-gauge shotgun blast without penetration of the cabinet wall by any pellets.

Test Procedure - The cabinet, or a test panel of the same material and thickness as the cabinet's surface, shall be subjected to a blast from a 2-3/4 inch, maximum-load, 12-gauge shotgun shell fired from a 28-inch modified choke barrel. A 1-ounce or 1-1/8 ounce (as available) load, No. 6 steel shot load shall be fired at a distance of 15m (50 ft) perpendicular to the cabinet's vertical surface or test panel, where

2-3/4 inch = length of shot shell

maximum-load = universal measure of gunpowder load within shot shell

28-inch = length of modified choke shotgun barrel

1-ounce (or 1-1/8 ounce) = weight of steel shot load within shot shell

No. 6 = size of steel shot (2.79 mm or 0.110 inch diameter).

**CR3-201** [163] Some customers require additional bullet resistance. The customer will specify the level of resistance and performance desired.

Typical customer requirements may be

- ... • Resistance to a 22-caliber long rifle bullet, hollow point or standard lead round nose, fired at a distance of 15 m (50 ft)
- ... • Resistance to a 30-06 caliber, 180 grain sharp-nosed soft point bullet fired at a distance of 46 m (50 yards).

### 3.33 Fire Resistance

**R3-202** [164] Cabinets shall maintain internal temperatures that preclude ignition of equipment inside when subjected to the simulated brush fire test. Following testing, there shall be no evidence of ignition, melting, burning or structural damage sufficient to impair equipment service. Exterior painted finishes may be blistered, peeled or burned off.

Test Procedure - A test cabinet shall be installed in the standard field arrangement. Cabinet cooling fans shall be in operation during this test. US No. 1 wheat straw shall be taken from a bale and placed on the ground around the cabinet base for a horizontal distance of 1 m (3 ft) from all vertical cabinet surfaces. The straw shall be placed at



a rate of 1.5 lbs/ft<sup>2</sup>, at a uniform depth around the cabinet. (As a guideline, the straw should be placed at an approximate depth of 4 inches. This final depth may be achieved by controlling the density of the loose straw, using a temporary manual compaction process, as necessary.) For a pole or wall mounted cabinet, the straw shall also extend beneath the cabinet, which, for the purpose of this test, shall be mounted at the manufacturer's recommended height, on a fire resistant pole or other simulated mounting arrangement. The material shall be ignited and permitted to burn fully. Upon cooling, the cabinet and its contents shall be inspected on the inside and outside. Photographs, taken immediately before the test, shall be provided that clearly indicate the application of the straw including its location relative to the cabinet.

### 3.34 Corrosion Resistance

#### 3.34.1 Salt Fog

**R3-203** [165] All cabinet components shall be resistant to corrosion and all mechanical features (e.g., cabinet surfaces, gaskets, seals, hinges, locking mechanisms, door alignment and restrainers) shall continue to function and operate satisfactorily after exposure to salt fog for 30 days. Cooling fans shall operate for a minimum of 14 days during this exposure. Fans exposed for 30 days, while idle, shall operate for a minimum of one hour when powered after exposure. Following Test Procedure (a), there shall be no visible evidence of general corrosion, including red rust or white corrosion products, or various forms of local corrosion, including stress corrosion, cracking, and pitting, exclusive of any surface scratches or nicks noted prior to testing. A steel cabinet shall have a rust grade of 9 or better per ASTM D 610<sup>[39]</sup>. If the cabinet is made of non-metallic material, there shall be no signs of degradation. (Mounting hardware meeting **R3-11** is excluded from this requirement.)

Test Procedures -

- ...
- a. The entire cabinet shall be placed in an environmental test chamber and exposed to a salt fog spray for 30 days, consistent with GR-2836-CORE<sup>[40]</sup> and in accordance with ASTM B 117. Fans, used to circulate outside air (i.e., heat exchanger fans), shall be in operation during this exposure. If any of the fans should fail prior to 14 days, the time to failure shall be noted. At the end of the test period, the cabinet shall be removed from the chamber, thoroughly washed in warm, clear water and examined internally and externally for corrosion and physical damage.

- ...
- b. Fans, used to circulate outside air (i.e., heat exchanger fans), shall be exposed to salt fog as described above while idle for 30 days. The fans may be either mounted in the cabinet or oriented as they would be in the cabinet during this test period. After the 30-day period, the fans shall be removed from the salt fog chamber and shall be energized. The fans shall operate at rated speed for a minimum of one hour after this exposure. Time to failure, if less than one hour, shall be noted.

**Note:** Excessive salt build-up may cause rotor lock. It is acceptable to clean away the salt deposit (i.e., rinsing with de-ionized water) in order to continue the latter test procedure.

### 3.34.2 Temperature Cycling/High Humidity

**R3-204** [166] All cabinet components shall be resistant to corrosion and all mechanical features (e.g., cabinet surfaces, gaskets, seals, hinges, locking mechanisms, door alignment and restrainers) shall continue to function and operate satisfactorily after exposure to temperature cycling and humidity. At the end of the test period, the cabinet shall be examined internally and externally. There shall be no visible evidence of general corrosion, including red rust or white corrosion products, or various forms of local corrosion, including stress corrosion, cracking, and pitting, exclusive of any surface scratches or nicks noted prior to testing. A steel cabinet shall have a rust grade of 9 or better per ASTM D 610. If the cabinet is made of non-metallic material, there shall be no signs of degradation. (Mounting hardware meeting **R3-11** is excluded from this requirement.)

Test Procedure - The cabinet shall be placed in an environmental test chamber and subjected to 40 twelve-hour cycles from 4.4°C (40°F) to 60°C (140°F) and return to 4.4°C (40°F), as indicated in [Figure 3-5](#). Each temperature extreme shall be maintained for a period of 3 hours. A relative humidity of 90-95% shall be maintained for temperatures below 32°C (90°F). At temperatures above 32°C (90°F), the relative humidity may be limited to that corresponding to a specific humidity of 0.024 kg of water per kg of dry air. During the period of descending temperatures – i.e., 32°C (90°F) to 4.4°C (40°F) – the relative humidity shall be 80-95%.

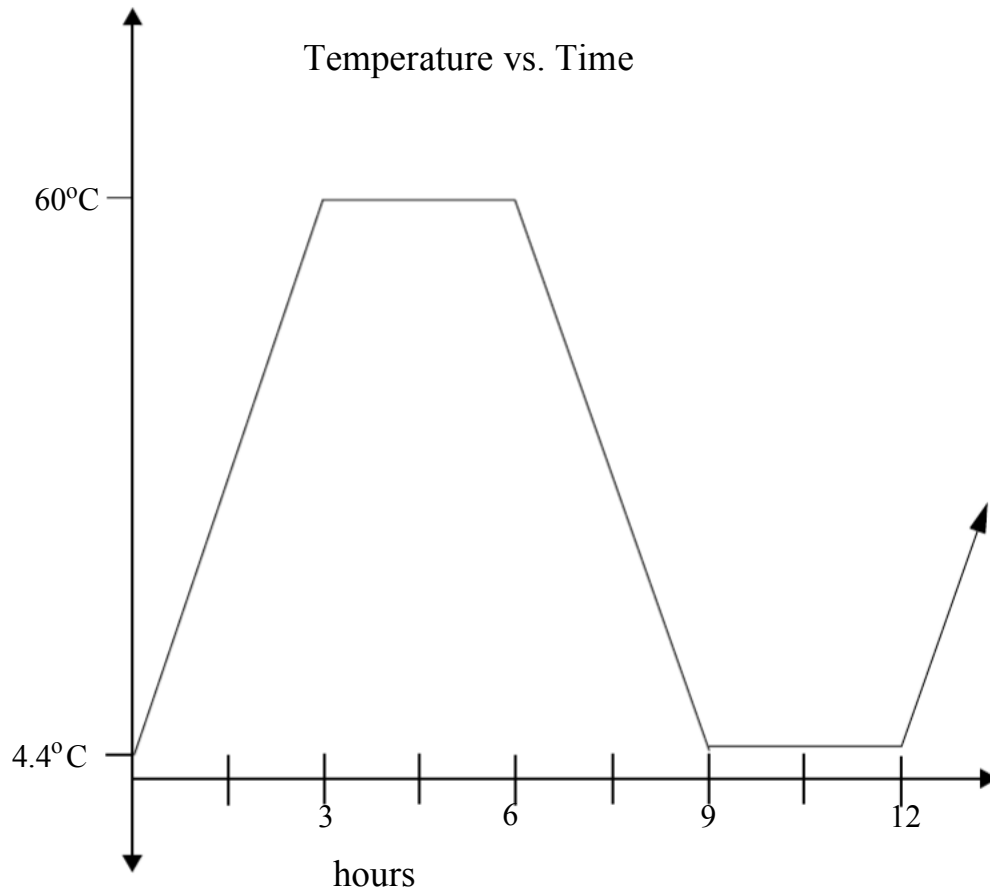

**Figure 3-5.** Temperature Cycle - Temperature Cycling/High Humidity

### 3.35 Shock and Vibration

#### 3.35.1 Transportation Shock

**R3-205** [167] A packaged cabinet, with contents as normally packaged for shipment, shall withstand the handling drop tests outlined in Section 5.3.1 of GR-63-CORE<sup>[1]</sup>. Damage shall be limited to that which would not impair proper installation or the functioning of door hinges, locks or internal components. Upon completion of test, any voltage breakdown (“hi-pot”) tests performed on the cabinet before shipment must be repeated to verify no degradation occurred.

#### 3.35.2 Transportation Shock (Rail)

**CR3-206** [168] Packaged cabinets, weighing more than 91 kg (200 lbs) and intended for shipment by rail, shall withstand the impact loads resulting from railroad car coupling. Damage shall be limited to that which would not impair proper installation or the functioning of door hinges, locks or internal components. Upon completion of test, any voltage breakdown tests performed on the cabinet before shipment must be repeated to verify no degradation occurred.

Test Procedure - A packaged cabinet, with contents as normally packaged, shall be mounted to the surface of a horizontal shock machine and subjected to one 30-g, 20-ms half-sine pulse on each face that might be perpendicular to the longitudinal axis of a railroad car during shipment by rail.

#### 3.35.3 Transportation Vibration

**R3-207** [169] A packaged cabinet, with contents as normally packaged for shipment, shall withstand the loads applied by simulated transportation vibration using the procedures outlined in Section 5.4.3 of GR-63-CORE. This exposure shall not result in damage to, or loosening of, component parts. Upon completion of test, any voltage breakdown tests performed on the cabinet before shipment must be repeated to verify no degradation occurred.

#### 3.35.4 Installation Shock

**R3-208** [170] An unpackaged cabinet, with contents as normally packaged, shall withstand the installation drop tests outlined in Section 5.3.2 of GR-63-CORE. Damage shall be limited to that which would not impair proper installation or the functioning of door hinges, locks or

internal components. Upon completion of test, any voltage breakdown tests performed on the cabinet before shipment must be repeated to verify no degradation occurred.

### **3.35.5 Environmentally Induced Vibration**

**CR3-209** [171] Some customers require that a cabinet, equipped with operating electronics and equipment, shall withstand the loads resulting from local environmental conditions without suffering electronic malfunction, mechanical damage, or loosening of component parts. For this purpose, the office vibration test procedure outlined in Section 5.4.2 of GR-63-CORE shall be used. The cabinet supplier shall provide the required operating characteristics for the housed electronics after exposure to this test.

### **3.35.6 Earthquake Resistance**

**CR3-210** [172] Some customers require that a cabinet installed to its concrete mounting pad or pole, using the cabinet manufacturer's recommended specifications and procedures, and equipped with electronics and equipment, shall meet the physical performance and functional criteria outlined in Sections 4.4.1.2 and 4.4.1.3 of GR-63-CORE.



## Appendix A: Observational Standard for Evaluating Dust Accumulation

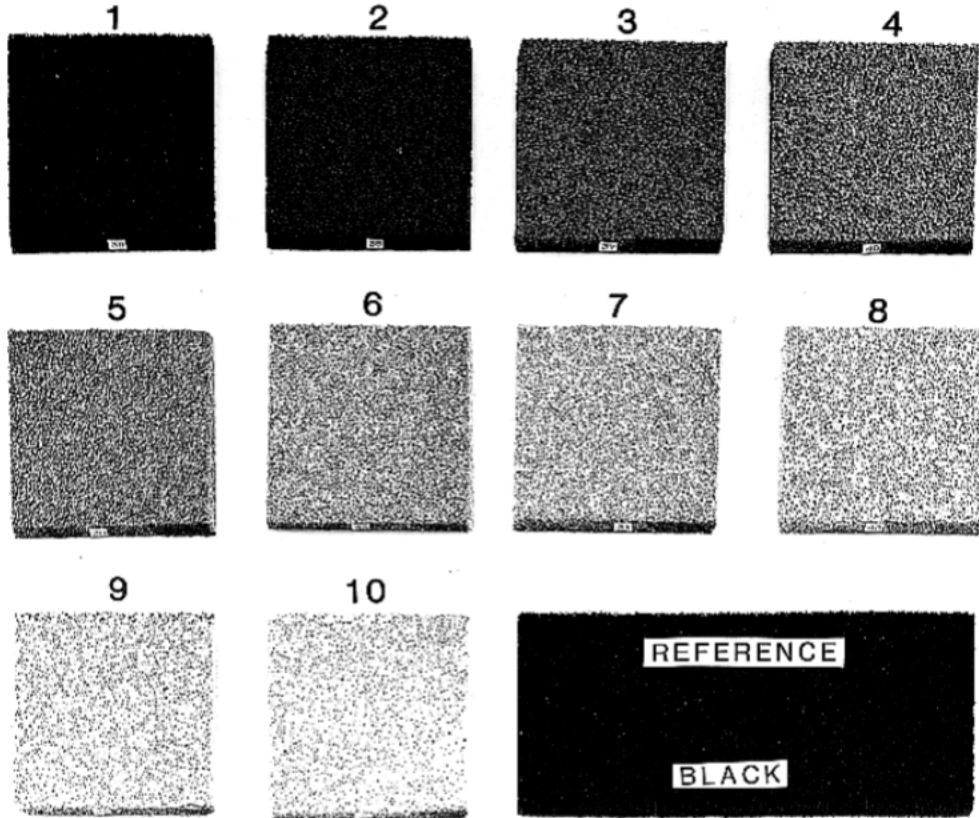





## References

1. **GR-63-CORE**, *Network Equipment-Building System (NEBS) Requirements: Physical Protection (a module of LSSGR, FR-64; TSGR, FR-440; and NEBS, FR-2063)*.
2. **GR-13-CORE**, *Generic Requirements for Pedestal Terminal Closures*.
3. **GR-26-CORE**, *Generic Requirements for Controlled Environment Vaults (CEVs)*.
4. **GR-43-CORE**, *Generic Requirements for Telecommunications Huts*.
5. **TR-NWT-000937**, *Generic Requirements for Building Entrance Terminals*.
6. **GR-950-CORE**, *Generic Requirements for Optical Network Unit (ONU) Closures*.
7. **GR-2832-CORE**, *Generic Requirements for Walk-In Cabinets*.
8. **GR-209-CORE**, *Generic Requirements for Product Change Notices*.
9. **ASTM A 153**, *Standard Specification for Zinc Coating (Hot -Dip) on Iron and Steel Hardware*, ASTM.
10. **ASTM D 56**, *Standard Test Method for Flash Point by Tag Closed Tester*, ASTM.
11. **ASTM D 1693**, *Standard Test Method for Environmental Stress Cracking of Ethylene Plastics*, ASTM.
12. **UL 94**, *Test for Flammability of Plastic Materials for Parts in Devices and Appliances, Vertical Burning Test for Classifying Materials 94 V-0, 94 V-1, or 94 V-2*, Underwriters Laboratories.
13. **UL 1581**, *Reference Standard for Electrical Wires, Cables and Flexible Cords*, Underwriters Laboratories.
14. **UL 746C**, *Polymeric Materials - Use in Electrical Equipment Evaluations*, Underwriters Laboratories.
15. **ASTM G 21**, *Standard Practice for Determining Resistance of Synthetic Polymeric Materials to Fungi*, ASTM.
16. **ASTM G 53**, *Standard Practice for Operating Light- and Water-Exposure Apparatus (Fluorescent UV-Condensation Type) for Exposure of Nonmetallic Materials*, ASTM.
17. **ASTM D 638**, *Standard Test Method for Tensile Properties of Plastics*, ASTM.
18. **ASTM D 518**, *Standard Test Method for Rubber Deterioration-Surface Cracking*, ASTM.

19. **ASTM D 1149**, *Standard Test Method for Rubber Deterioration-Surface Ozone Cracking*, ASTM.
20. **ASTM D 2244**, *Standard Test Method for Calculation of Color Differences From Instrumentally Measured Color Coordinates*, ASTM.
21. **ASTM D 523**, *Standard Test Method for Specular Gloss*, ASTM.
22. **ASTM D 2197**, *Standard Test Method for Adhesion of Organic Coatings by Scrape Adhesion*, ASTM.
23. **ASTM D 2794**, *Standard Test Method for Resistance of Organic Coatings to the Effects of Rapid Deformation (Impact)*, ASTM.
24. **ASTM D 1654**, *Standard Test Method for Evaluation of Painted or Coated Specimens Subjected to Corrosive Environments*, ASTM
25. **ASTM B 117**, *Standard Method of Salt Spray (Fog) Testing*, ASTM.
26. **UL 497**, *Protectors for Paired Conductor Communications Circuits*, Underwriters Laboratories.
27. **TR-NWT-001293**, *Generic Requirements for Permanent Engine-Generators for Remote Electronic Sites*.
28. **ANSI/IEEE C62.41**, *IEEE Guide for Surge Voltages in Low-Voltage AC Power Circuits*, ANSI/IEEE.
29. **TR-NWT-001011**, *Generic Requirements for Surge Protective Devices (SPDs) on AC Power Circuits*.
30. **UL 50**, *Enclosure for Electronic Equipment*, 11<sup>th</sup> Edition.
31. **TA-NWT-000406**, *DC Bulk Power System for Confined Locations*.
32. **NBS Report 81-2320**, *A Heat Transfer Analysis of Scald Injury*.
33. **GR-839-CORE**, *Generic Requirements for Supplier-Provided Training (a module of LSSGR, FR-64; TSGR, FR-440; and OTGR, FR-439)*.
34. **GR-1252-CORE**, *Quality System Generic Requirements for Hardware (a module of RQGR, FR-796)*.
35. **MIL-STD-810E**, *Environmental Test Methods and Engineering Guidelines*, Department of Defense.
36. **ANSI 1.4**, *General Purpose Sound Level Meter*, ANSI.
37. **ANSI 1.18**, *Measurement of Sound Pressure Levels*, ANSI.
38. **ANSI/ASCE 7-95**, *Minimum Design Loads for Buildings and Other Structures*, ANSI/ASCE.
39. **ASTM D 610**, *Standard Method of Evaluating Degree of Rusting on Painted Steel Surfaces*, ASTM.

40. **GR-2836-CORE**, *Generic Requirements for Assuring Corrosion Resistance of Telecommunications Equipment in the Outside Plant.*

**NOTE:**

All Telcordia documents are subject to change, and their citation in this document reflects the most current information available at the time of this printing. Readers are advised to check current status and availability of all documents.

**To Contact Telcordia**

Telcordia Customer Service  
8 Corporate Place, Room 3A-184  
Piscataway, New Jersey 08854-4156  
1-800-521-2673 (USA and Canada)  
1-732-699-5800 (all others)  
1-732-336-2559 (FAX)

**To Order Documents**

- Perform the following steps to order from the on-line catalog:
  1. Enter the URL line: ***telecom-info.telcordia.com***
  2. Click on the ***Search*** button located on top
  3. In the ***Keywords*** field, enter the document number (or keywords), then click on ***Submit Search***.  
or . . .
    1. Enter the above URL line
    2. Click on the ***Browse*** button located on top, then click on the subject of interest.
- Telcordia employees should perform the following steps:
  1. Access the Telcordia Internal Home Page
  2. Click on the ***Services*** button located on the left
  3. Click on ***DOCS - Telcordia Product Catalog***
  4. Enter data in one or more of the fields (e.g., enter a document number in the ***Product Number*** field), then follow the instructions to search the on-line catalog.



## Requirement-Object Index

[1]	R3-1	Page 3-1	[44]	R3-46	Page 3-11
[2]	R3-2	Page 3-1	[45]	R3-47	Page 3-11
[3]	R3-3	Page 3-1	[46]	R3-48	Page 3-11
[4]	R3-4	Page 3-1	[47]	R3-49	Page 3-12
[5]	R3-5	Page 3-1	[48]	R3-50	Page 3-12
[6]	R3-6	Page 3-1	[49]	R3-51	Page 3-12
[7]	R3-7	Page 3-1	[50]	R3-52	Page 3-12
[8]	R3-8	Page 3-2	[51]	R3-53	Page 3-12
[9]	CR3-10	Page 3-2	[52]	R3-54	Page 3-12
[12]	CR3-13	Page 3-3	[53]	CR3-55	Page 3-12
[13]	R3-14	Page 3-3	[55]	R3-56	Page 3-12
[14]	CR3-15	Page 3-3	[56]	R3-57	Page 3-13
[15]	R3-16	Page 3-3	[57]	R3-58	Page 3-13
[16]	R3-17	Page 3-3	[58]	R3-59	Page 3-13
[17]	R3-20	Page 3-4	[59]	R3-60	Page 3-13
[18]	R3-21	Page 3-4	[60]	O3-61	Page 3-14
[19]	R3-22	Page 3-4	[61]	CR3-63	Page 3-14
[20]	R3-23	Page 3-4	[62]	R3-64	Page 3-14
[21]	R3-24	Page 3-5	[63]	CR3-65	Page 3-14
[22]	R3-25	Page 3-5	[64]	R3-67	Page 3-14
[23]	R3-26	Page 3-5	[65]	CR3-68	Page 3-14
[25]	R3-27	Page 3-5	[66]	CR3-69	Page 3-14
[26]	R3-28	Page 3-6	[67]	R3-70	Page 3-15
[27]	R3-29	Page 3-6	[68]	CR3-71	Page 3-15
[28]	R3-30	Page 3-6	[69]	R3-72	Page 3-15
[29]	R3-31	Page 3-6	[70]	CR3-73	Page 3-15
[30]	R3-32	Page 3-6	[71]	R3-81	Page 3-16
[31]	R3-33	Page 3-7	[72]	R3-82	Page 3-16
[32]	R3-34	Page 3-7	[73]	R3-83	Page 3-16
[33]	R3-35	Page 3-7	[74]	R3-88	Page 3-17
[34]	R3-11	Page 3-2	[75]	R3-89	Page 3-17
[35]	R3-12	Page 3-2	[77]	R3-90	Page 3-17
[36]	R3-36	Page 3-8	[78]	R3-91	Page 3-17
[37]	R3-37	Page 3-8	[79]	R3-92	Page 3-18
[38]	R3-38	Page 3-8	[80]	CR3-93	Page 3-18
[39]	R3-39	Page 3-8	[81]	R3-94	Page 3-18
[40]	R3-40	Page 3-8	[82]	R3-95	Page 3-18
[41]	R3-41	Page 3-8	[83]	R3-96	Page 3-18
[42]	R3-42	Page 3-8	[84]	R3-97	Page 3-18
[43]	R3-45	Page 3-11	[85]	O3-98	Page 3-18
			[86]	R3-99	Page 3-18

[87]	R3-100	Page 3-19	[134]	R3-168	Page 3-27
[88]	R3-101	Page 3-19	[135]	R3-169	Page 3-27
[89]	R3-105	Page 3-19	[136]	R3-171	Page 3-27
[90]	R3-106	Page 3-19	[137]	R3-172	Page 3-27
[91]	R3-107	Page 3-19	[138]	R3-173	Page 3-27
[92]	R3-108	Page 3-19	[139]	R3-174	Page 3-28
[93]	CR3-109	Page 3-19	[140]	O3-175	Page 3-28
[94]	R3-110	Page 3-20	[141]	O3-176	Page 3-28
[95]	R3-111	Page 3-20	[142]	R3-177	Page 3-28
[96]	CR3-113	Page 3-20	[143]	R3-178	Page 3-28
[97]	R3-114	Page 3-20	[144]	CR3-179	Page 3-28
[98]	R3-115	Page 3-20	[145]	R3-180	Page 3-28
[99]	R3-116	Page 3-20	[146]	R3-181	Page 3-28
[101]	R3-124	Page 3-21	[147]	R3-182	Page 3-28
[102]	CR3-125	Page 3-21	[148]	CR3-184	Page 3-29
[103]	R3-126	Page 3-21	[149]	R3-185	Page 3-29
[104]	R3-127	Page 3-21	[150]	R3-186	Page 3-29
[105]	R3-128	Page 3-22	[152]	R3-187	Page 3-30
[107]	R3-129	Page 3-22	[153]	CR3-189	Page 3-36
[108]	R3-130	Page 3-22	[154]	CR3-190	Page 3-36
[109]	O3-131	Page 3-22	[155]	R3-191	Page 3-36
[110]	R3-132	Page 3-22	[156]	CR3-192	Page 3-39
[111]	CR3-133	Page 3-23	[157]	R3-196	Page 3-42
[112]	CR3-134	Page 3-23	[158]	R3-195	Page 3-41
[113]	R3-135	Page 3-23	[159]	R3-193	Page 3-39
[115]	CR3-136	Page 3-23	[160]	R3-198	Page 3-45
[117]	R3-137	Page 3-23	[161]	R3-199	Page 3-47
[118]	R3-138	Page 3-23	[162]	R3-200	Page 3-48
[119]	R3-153	Page 3-25	[163]	CR3-201	Page 3-48
[120]	R3-154	Page 3-25	[164]	R3-202	Page 3-48
[121]	CR3-155	Page 3-25	[165]	R3-203	Page 3-49
[122]	R3-197	Page 3-43	[166]	R3-204	Page 3-50
[123]	R3-157	Page 3-25	[167]	R3-205	Page 3-52
[124]	R3-158	Page 3-26	[168]	CR3-206	Page 3-52
[125]	CR3-159	Page 3-26	[169]	R3-207	Page 3-52
[126]	R3-160	Page 3-26	[170]	R3-208	Page 3-52
[127]	R3-161	Page 3-26	[171]	CR3-209	Page 3-53
[128]	R3-162	Page 3-26	[172]	CR3-210	Page 3-53
[129]	R3-163	Page 3-26	[173]	R3-9	Page 3-2
[130]	R3-164	Page 3-27	[174]	R3-18	Page 3-4
[131]	R3-165	Page 3-27	[175]	R3-19	Page 3-4
[132]	R3-166	Page 3-27	[176]	R3-43	Page 3-9
[133]	R3-167	Page 3-27	[177]	O3-44	Page 3-11

[178]	CR3-62	Page 3-14	[200]	R3-122	Page 3-21
[179]	R3-66	Page 3-14	[201]	CR3-123	Page 3-21
[180]	CR3-74	Page 3-15	[202]	R3-139	Page 3-24
[181]	R3-75	Page 3-15	[203]	R3-140	Page 3-24
[182]	CR3-76	Page 3-15	[204]	R3-141	Page 3-24
[183]	R3-77	Page 3-16	[205]	R3-142	Page 3-24
[184]	R3-78	Page 3-16	[206]	R3-143	Page 3-24
[185]	R3-79	Page 3-16	[207]	R3-144	Page 3-24
[186]	R3-80	Page 3-16	[208]	R3-145	Page 3-24
[187]	O3-84	Page 3-17	[209]	R3-146	Page 3-24
[188]	O3-85	Page 3-17	[210]	R3-147	Page 3-24
[189]	O3-86	Page 3-17	[211]	R3-148	Page 3-24
[190]	R3-87	Page 3-17	[212]	R3-149	Page 3-24
[191]	CR3-102	Page 3-19	[213]	R3-150	Page 3-24
[192]	R3-103	Page 3-19	[214]	R3-151	Page 3-24
[193]	R3-104	Page 3-19	[215]	R3-152	Page 3-25
[194]	CR3-112	Page 3-20	[216]	R3-156	Page 3-25
[195]	R3-117	Page 3-20	[217]	R3-170	Page 3-27
[196]	R3-118	Page 3-20	[218]	O3-183	Page 3-29
[197]	R3-119	Page 3-21	[219]	CR3-188	Page 3-36
[198]	R3-120	Page 3-21	[220]	O3-194	Page 3-40
[199]	CR3-121	Page 3-21			

