

MIL-STD-750D

METHOD 3161

THERMAL IMPEDANCE MEASUREMENTS FOR VERTICAL POWER MOSFET's
(DELTA SOURCE-DRAIN VOLTAGE METHOD)

1. **Purpose.** The purpose of this test method is to measure the thermal impedance of the MOSFET under the specified conditions of applied voltage, current, and pulse duration. The temperature sensitivity of the forward voltage of the source-drain diode is used as the junction temperature indicator. This method is particularly suitable to enhancement mode, power MOSFET's having relatively long thermal response times. This test method may be used to measure the thermal response of the junction to a heating pulse, to ensure proper die mountdown to its case, or the dc thermal resistance, by the proper choice of the pulse duration and magnitude of the heating pulse. The appropriate test conditions and limits are detailed in 5.

1.1 **Definitions.** The following symbols shall apply for the purpose of this test method:

- I_M : Current in the source-drain diode during measurement of the source-drain voltage.
- I_H : Heating current through the drain.
- V_H : Heating voltage between the drain and source.
- P_H : Magnitude of the heating power pulse applied to DUT in watts; the product of I_H and V_H .
- t_H : Heating time during which P_H is applied.
- VTC: Voltage-temperature coefficient of V_{SD} with respect to T_J ; in mV/°C.
- K: Thermal calibration factor, equal to reciprocal of VTC; in °C/mV.
- T_J : Junction temperature in degrees Celsius.
- T_{Ji} : Junction temperature in degrees Celsius before start of the power pulse.
- T_{Jf} : Junction temperature in degrees Celsius at the end of the power pulse.
- T_X : Reference temperature in degrees Celsius.
- T_{Xi} : Initial reference temperature in degrees Celsius.
- T_{Xf} : Final reference temperature in degrees Celsius.
- V_{SD} : Source-drain diode voltage in millivolts.
- V_{SDi} : Initial source-drain voltage in millivolts.
- V_{SDf} : Final source-drain voltage in millivolts.
- t_{MD} : Measurement delay time is defined as the time from the removal of heating power P_H to the start of the V_{SD} measurement.
- t_{SW} : Sample window time during which final V_{SD} measurement is made.
- VGS(M): Gate-source voltage applied during the initial and final measurement periods.
- $Z_{\theta JX}$: Transient junction-to-reference point thermal impedance in degrees Celsius/watt. $Z_{\theta JX}$ for specified power pulse duration is:

$$Z_{\theta JX} = \frac{(T_{Jf} - T_{Ji} - \Delta T_X)}{P_H}$$

Where: ΔT_X = Change in reference point temperature during the heating pulse (see 4.2 and 4.4).
For short heating pulses, e.g., die attach evaluation, this term is normally negligible.)

2. Apparatus. The apparatus required for this test shall include the following as applicable to the specified test procedure:

- a. A thermocouple for measuring the case temperature at a specified reference point. The recommended reference point shall be located on the case under the heat source. Thermocouple material shall be copper-constantan (type T) or equivalent. The wire size shall be no larger than AWG size 30. The junction of the thermocouple shall be welded to form a bead rather than soldered or twisted. The accuracy of the thermocouple and its associated measuring system shall be $\pm 0.5^\circ\text{C}$. Proper mounting of the thermocouple to ensure intimate contact to the reference point is critical for system accuracy.
- b. A controlled temperature environment capable of maintaining the case temperature during the device calibration procedure to within $\pm 1^\circ\text{C}$ over the temperature range of $+23^\circ\text{C}$ to $+100^\circ\text{C}$, the recommended temperatures for measuring K factor.
- c. A K factor calibration setup, as shown on figure 3161-1, that measures V_{SD} for a specified value of I_M in an environment in which temperature is both controlled and measured. A temperature controlled, circulating fluid bath may be used. The current source must be capable of supplying I_M with an accuracy of ± 1 percent. The voltage source must be capable of supplying a stable $V_{GS(M)}$ in the range of -1 to -5 V (opposite polarity for p-channel devices). This voltage is applied in such a way as to turn the DUT off (i.e., gate negative with respect to source for n-channel device). The voltage measurement of V_{SD} shall be made using kelvin contacts and with voltmeters capable of 1 mV resolution. The device-to-current source wire size shall be sufficient to handle the measurement current (AWG size 22 stranded is typically used for up to 100 mA).

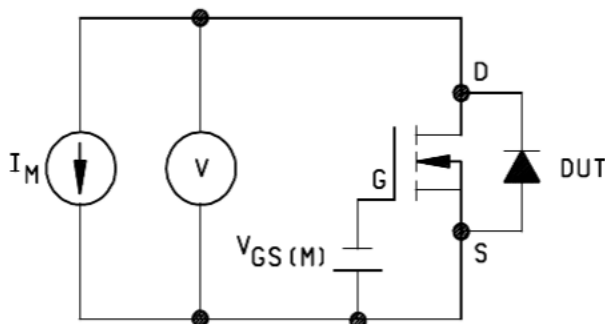
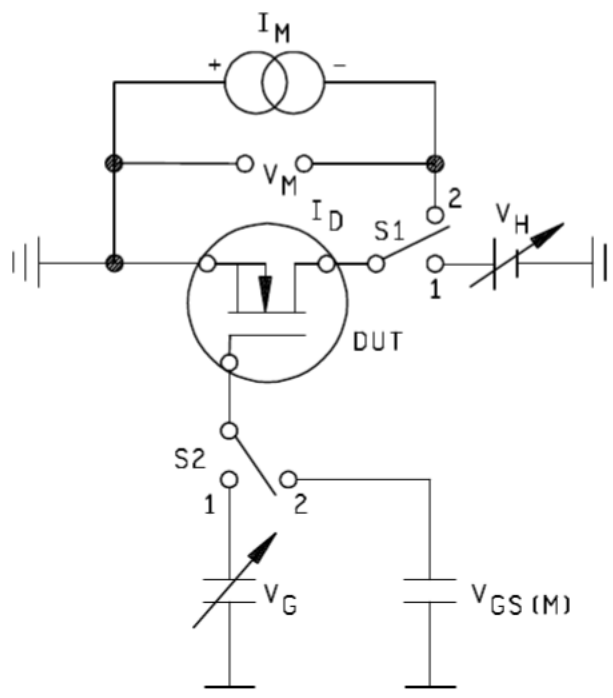

FIGURE 3161-1. K-factor calibration setup.

- d. A test circuit used to control the device and to measure the temperature using the forward voltage of the source-drain diode as the temperature sensing parameter as shown on figure 3161-2. Polarities shown are for n-channel devices but the circuit may be used for p-channel types by reversing the polarities of the voltage and current sources.
- e. Suitable sample-and-hold voltmeter or oscilloscope to measure source-drain forward voltage at specified times. V_{SD} shall be measured to within 5 mV, or within 5 percent of $(V_{SDi} - V_{SDf})$, whichever is less.



NOTES:

1. The circuit consists of the DUT, three voltage sources, a current source, and two electronic switches. During the heating phase of the measurement, switches S1 and S2 are in position 1. The values of V_G and V_D are adjusted to achieve the desired values of I_D and V_{DS} for the P_H "heating" condition.
2. To measure the initial and post heating pulse junction temperatures of the DUT, switches S1 and S2 are each switched to position 2. This puts the gate at the measurement voltage level $V_{GS(M)}$ and connects the current source I_M to supply forward measurement current to the source-drain diode. The polarity of the current source is such that the voltage applied to the MOSFET source and drain are opposite to those employed during normal MOSFET operation. Figures 3161-3 and 3161-4 show the waveforms associated with the three segments of the test.

FIGURE 3161-2. Thermal impedance measurement circuit (source-drain diode method).

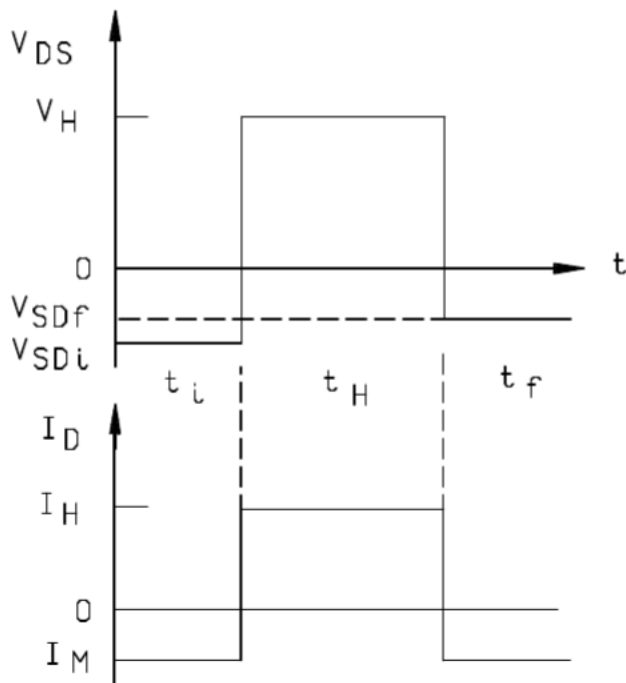

FIGURE 3161-3. Device waveforms during the three segments of the thermal transient test.

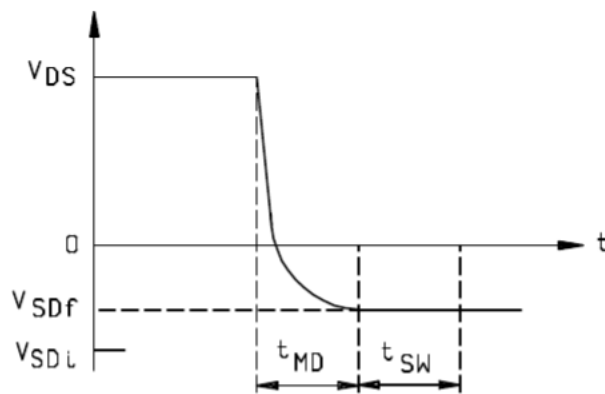

FIGURE 3161-4. Second V_{SD} measurement waveform.

NOTE: The value of t_{MD} is critical to the accuracy of the measurement and must be properly specified in order to ensure measurement repeatability. Note that some test equipment manufacturers include the sample and hold window time t_{SW} within their t_{MD} specification.

3. Measurement of the TSP. The required calibration of V_{SD} versus T_J is accomplished by monitoring V_{SD} for the required value of I_M as the heat sink temperature (and thus the DUT temperature) is varied by external heating. The magnitude of I_M shall be chosen so that V_{SD} is a linearly decreasing function over the expected range of T_J during the power pulse. I_M must be large enough to ensure that the source-drain junction is turned on but not so large as to cause any significant self-heating. (This will normally be 10 mA for small power devices and up to 100 mA for large ones.) The $V_{GS(M)}$ value must be large enough to decouple the gate from controlling the DUT; typical values are in the 1 to 5 V range. An example calibration curve is shown on figure 3161-5.

3.1 Measurement of die attachment integrity. When screening to ensure proper die attachment integrity within a given lot or in a group of same type number devices of one manufacturer, this calibration step is not required. In such cases, the measure of thermal response may be ΔV_{SD} for a short heating pulse, and the computation of ΔT_J or $Z_{\theta JX}$ is not necessary. (For this purpose, t_H shall be 10 ms for TO-39 size packages and 100 ms for TO-3 packages.)

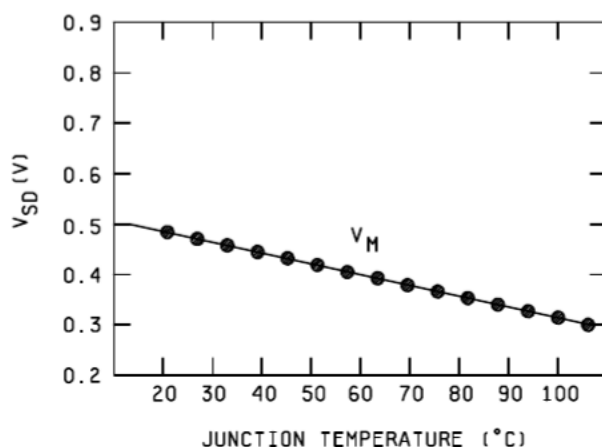

FIGURE 3161-5. Example curve of V_{SD} versus T_J .

3.2 K factor calibration. A K factor calibration (which is the reciprocal of VTC or the slope of the curve on figure 3161-4) can be defined as:

$$K = \frac{I}{VTC} = \left| \frac{T_{J1} - T_{J2}}{V_{SD1} - V_{SD2}} \right| \gamma C / mV$$

It has been found experimentally that the K factor variation for all devices within a given device type class is small. The usual procedure is to perform a K factor calibration on a 10 to 12 piece sample from a device lot and determine the average K and standard deviation (σ). If σ is less than or equal to three percent of the average value of K, then the average value of K can be used for all devices within the lot. If σ is greater than three percent of the average value of K, then all the devices in the lot shall be calibrated and the individual values of K shall be used in thermal impedance calculations or in correcting ΔV_{SD} values for comparison purposes.

4. Test procedure.

4.1 Calibration. K factor must be determined according to the procedure outlined in 3., except as noted in 3.1.

4.2 Reference point temperature. The reference point is usually chosen to be on the bottom of the transistor case directly below the semiconductor chip in a TO-204 metal can or in close proximity to the chip in other styles of packages. Reference temperature point location must be specified and its temperature shall be monitored using the thermocouple mentioned in 2.a. during the preliminary testing. If it is ascertained that T_X increases by more than $+5^\circ\text{C}$ of measured junction temperature rise during the power pulse, then either the heating power pulse magnitude must be decreased, the DUT must be mounted in a temperature controlled heat sink, or the calculated value of thermal impedance must be corrected to take into account the thermal impedance of the reference point to the cooling medium or heat sink. Temperature measurements for monitoring, controlling, and correcting for reference point temperature changes are not required if the t_H value is low enough to ensure that the heat generated within the DUT has not had time to propagate through the package. Typical values of t_H for this case are in the 10 ms to 500 ms range, depending on DUT package type and material.

4.3 Thermal measurements. The following sequence of tests and measurements must be made:

- a. Prior to the power pulse:
 - (1) Establish reference point temperature (T_{Xi}).
 - (2) Apply measurement current (I_M).
 - (3) Apply gate-source measurement voltage ($V_{GS(M)}$).
 - (4) Measure source-drain voltage drop (V_{SDi}) (a measurement of the initial junction temperature).
- b. Heating pulse parameters:
 - (1) Apply drain-source heating voltage (V_H).
 - (2) Apply drain heating current (I_H) as required by adjustment of gate-source voltage.
 - (3) Allow heating condition to exist for the required heating pulse duration (t_H).
 - (4) Measure reference point temperature (T_{Xf}) at the end of heating pulse duration.

(NOTE: T_X measurements are not required if the t_H value meets the requirements stated in 4.2.)

- c. Post power pulse measurements:
 - (1) Apply measurement current (I_M).
 - (2) Apply gate-source measurement voltage ($V_{GS(M)}$).
 - (3) Measurement source-drain voltage drop (V_{SDf}) (a measurement of the final junction temperature).
 - (4) Time delay between the end of the power pulse and the completion of the V_{SDf} measurement as defined by the waveform of figure 3161-4 in terms of $t_{MD} + t_{SW}$.

4.4 Thermal impedance. The value of thermal impedance ($Z_{\theta JX}$) is calculated from the following formula:

$$Z_{\theta JX} = \frac{\Delta T_J}{P_H} = \left| \frac{K (V_{SDf} - V_{SDi})}{(I_H) (V_H)} \right| \gamma C / W$$

This value of thermal impedance will have to be corrected if T_{Xf} is greater than T_{Xi} by +5°C. The correction consists of subtracting out the component of thermal impedance due to the thermal impedance from the reference point (typically the device case) to the cooling medium or heat sink. T_X measurements are not required if the t_H value meets the requirements stated in 4.2. This thermal impedance component has a value calculated as follows:

$$Z_{\theta X-HS} = \frac{\theta T_X}{P_H} = \frac{(T_{xf} - T_{xi})}{[(I_H)(V_H)]}$$

Where: HS = cooling medium or heat sink (if used).

Then: $Z_{\theta JX} | = Z_{\theta JX} | - Z_{\theta X-HS}$
 | |
 Corrected Calculated

Note: This last step is not necessary for die attach evaluation (see 3.1).

5. Test conditions and measurements to be specified and recorded.

5.1 K factor calibration.

5.1.1 Conditions data. Specify the following test conditions:

- Measuring current (I_M) (see detail specification).
- Gate-source voltage ($V_{GS(M)}$) (in the range of 0 V to -6 V).
- Initial junction temperature (T_{J1}): +25°C ±5°C.
- Final junction temperature (T_{Jf}): +100°C ±10°C.

5.1.2 Record data. Record the following data:

- Initial V_{SD} voltage.
- Final V_{SD} voltage.

5.1.3 Calculation data. Calculate K factor in accordance with the following equation:

$$K = \left| \frac{T_{J1} - T_{J2}}{V_{sd1} - V_{sd2}} \right| \text{ } \mu\text{C/mV}$$

5.1.4 Die attach procedure. K factor calibration (see 5.1) may not be necessary for die attachment evaluation (see 3.1).

5.2 Thermal impedance measurements.

5.2.1 Conditions data. Specify the following test conditions in the detail specification.

- Measuring current (I_M) (must be same as used for K factor calibration).
- Drain heating current (I_H).
- Heating time (t_H).
- Drain-source heating voltage (V_H).

- e. Measurement time delay (t_{MD}).
- f. Sample window time (t_{SW}).
- g. Gate-source voltage ($V_{GS(M)}$) (must be same as used for K factor calibration).

(NOTE: I_H and V_H are usually chosen so that P_H is approximately two-thirds of device rated power dissipation).

5.2.2 Record data. Record the following data:

- a. Initial reference temperature (T_{Xi}).
- b. Final reference temperature (T_{Xf}).
- c. T_X measurements are not required if the t_H value meets the requirements stated in 4.2.
- d. Calculate thermal impedance using the procedure and equations shown in 4.4.

5.2.2.1 ΔV_{SD} data. This parameter can either be read directly from suitable test instrumentation or calculated by taking the difference between initial and final values of V_{SD} (i.e., $\Delta V_{SD} = |V_{SD(i)} - V_{SD(f)}|$.)

5.2.3 Thermal resistance measurements. This is a thermal impedance measurement for the condition in which the heating time (t_H) has been applied long enough to ensure that the temperature drop from the device junction to the case reference point in accordance with 2.a. has reached equilibrium and no longer increases for greater values of t_H . In practical measurements, this condition can be assumed to exist when the rate of junction temperature change matches the rate of case temperature change.

5.3 Thermal response ΔV_{DS} measurements for screening. These measurements are made for t_H values that meet the intent of 3.1 and the requirements stated in 4.2.

5.3.1 Conditions data. Specify the following test conditions in the detail specification:

- a. Measuring current (I_M).
- b. Drain heating current (I_H).
- c. Heating time (t_H).
- d. Drain-source heating voltage (V_H).
- e. Measurement time delay (t_{MD}).
- f. Sample window time (t_{SW}).
- g. Gate-source voltage ($V_{GS(M)}$) (must be the same as used if and when K factor calibration is performed (see 5.3.2.1b)).

(The values of I_H and V_H are usually chosen equal to or greater than the values used for thermal impedance measurements.)

5.3.2 Specified limits. The following data is compared to the specified limits:

5.3.2.1 ΔV_{SD} data.

- a. Same as 5.2.2.1.
- b. Optionally calculate ΔT_J for comparison or screening purposes, or both, if the K factor results (see 3. and 5.1) produce a σ greater than three percent of the average value of K.

$$\Delta T_J = K (\Delta V_{SD}) \text{ in } ^\circ\text{C}$$

6. Summary. The following conditions shall be specified in the detail specification:

6.1 Thermal impedance.

- a. I_M measuring current.
- b. I_H drain heating current.
- c. t_H heating time.
- d. V_H drain-source heating voltage.
- e. t_{MD} measurement time delay.
- f. t_{SW} sample window time.

6.2 Thermal response ΔV_{SD} measurement.

- a. I_M measuring current.
- b. I_H drain heating current.
- c. t_H heating time.
- d. V_H drain-source heating voltage.
- e. t_{MD} measurement time delay.
- f. t_{SW} sample window time.